

**Pioneer**

# Service Manual

KEH-1800/X1M/UC

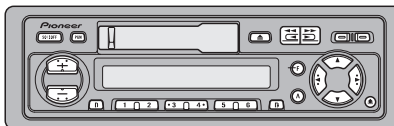

ORDER NO.  
**CRT2266**

HIGH POWER CASSETTE PLAYER WITH FM/AM TUNER

# KEH-1800

## KEH-1850

X1M/ES

X1M/UC

**NOTE:**

- See the separate manual CX-644(CRT1800) for the cassette mechanism description.
- The cassette mechanism assy employed in this model is one of 2M series.

## CONTENTS

1. SAFETY INFORMATION.....2	7. GENERAL INFORMATION.....34
2. EXPLODED VIEWS AND PARTS LIST .....2	7.1 PARTS .....34
3. SCHEMATIC DIAGRAM.....8	7.1.1 IC.....34
4. PCB CONNECTION DIAGRAM.....18	7.1.2 DISPLAY .....38
5. ELECTRICAL PARTS LIST.....26	7.2 DISASSEMBLY .....39
6. ADJUSTMENT .....32	7.3 BLOCK DIAGRAM .....40
	8. OPERATIONS AND SPECIFICATIONS.....41

**PIONEER ELECTRONIC CORPORATION** 4-1, Meguro 1-Chome, Meguro-ku, Tokyo 153-8654, Japan  
**PIONEER ELECTRONICS SERVICE INC.** P.O.Box 1760, Long Beach, CA 90801-1760 U.S.A.  
**PIONEER ELECTRONIC [EUROPE] N.V.** Haven 1087 Keetberglaan 1, 9120 Melsele, Belgium  
**PIONEER ELECTRONICS ASIACENTRE PTE.LTD.** 253 Alexandra Road, #04-01, Singapore 159936

# 1. SAFETY INFORMATION

## CAUTION

This service manual is intended for qualified service technicians; it is not meant for the casual do-it-yourselfer. Qualified technicians have the necessary test equipment and tools, and have been trained to properly and safely repair complex products such as those covered by this manual. Improperly performed repairs can adversely affect the safety and reliability of the product and may void the warranty. If you are not qualified to perform the repair of this product properly and safely; you should not risk trying to do so and refer the repair to a qualified service technician.

## WARNING

This product contains lead in solder and certain electrical parts contain chemicals which are known to the state of California to cause cancer, birth defects or other reproductive harm. Health & Safety Code Section 25249.6 - Proposition 65

# 2. EXPLODED VIEWS AND PARTS LIST

## 2.1 PACKING

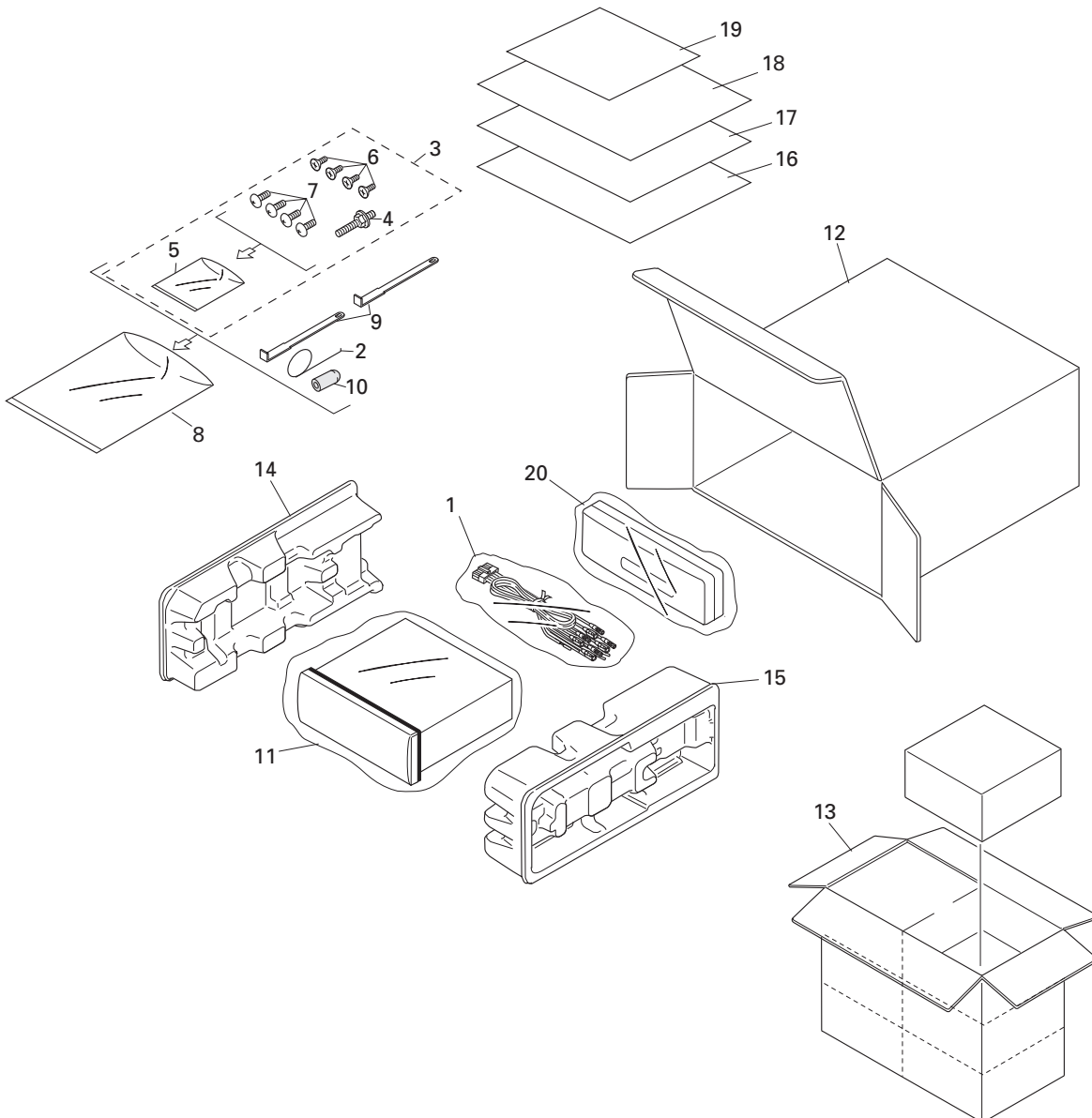

**NOTE:**

- Parts marked by "\*" are generally unavailable because they are not in our Master Spare Parts List.
- Screws adjacent to ∇ mark on the product are used for disassembly.

**● PACKING SECTION PARTS LIST**

Mark No.	Description	Part.No	
		KEH-1800/X1M/UC	KEH-1850/X1M/ES
	1 Cord Assy	CDE5805	CDE5805
	2 Spring	CBH1650	CBH1650
	3 Screw Assy	CEA2351	CEA2351
	4 Screw	CBA1304	CBA1304
*	5 Polyethylene Bag	CEG-127	CEG-127
	6 Screw	CRZ50P090FMC	CRZ50P090FMC
	7 Screw	TRZ50P080FMC	TRZ50P080FMC
*	8 Polyethylene Bag	CEG-158	CEG-158
	9 Handle	CNC5395	CNC5395
	10 Bush	CNV3930	CNV3930
	11 Polyethylene Bag	CEG1173	CEG-162
	12 Carton	CHG3624	CHG3625
	13 Contain Box	CHL3624	CHL3625
	14 Protector	CHP1622	CHP1622
	15 Protector	CHP1623	CHP1623
	16 Owner's Manual	CRD2815	CRD2817
	17 Owner's Manual	Not used	CRD2818
	18 Installation Manual	CRD2816	CRD2819
*	19 Card	ARY1048	Not used
	20 Case Assy	CXB3520	CXB3520

**● Owner's Manual, Installation Manual**

Model	Part No.	Language
KEH-1800/X1M/UC	CRD2815	English,French,Spanish
	CRD2816	English,French,Spanish
KEH-1850/X1M/ES	CRD2817	English,Spanish,Portuguese(B)
	CRD2818	Chinese,Arabic
	CRD2819	English,Spanish,Portuguese(B),Chinese,Arabic

## 2.2 EXTERIOR

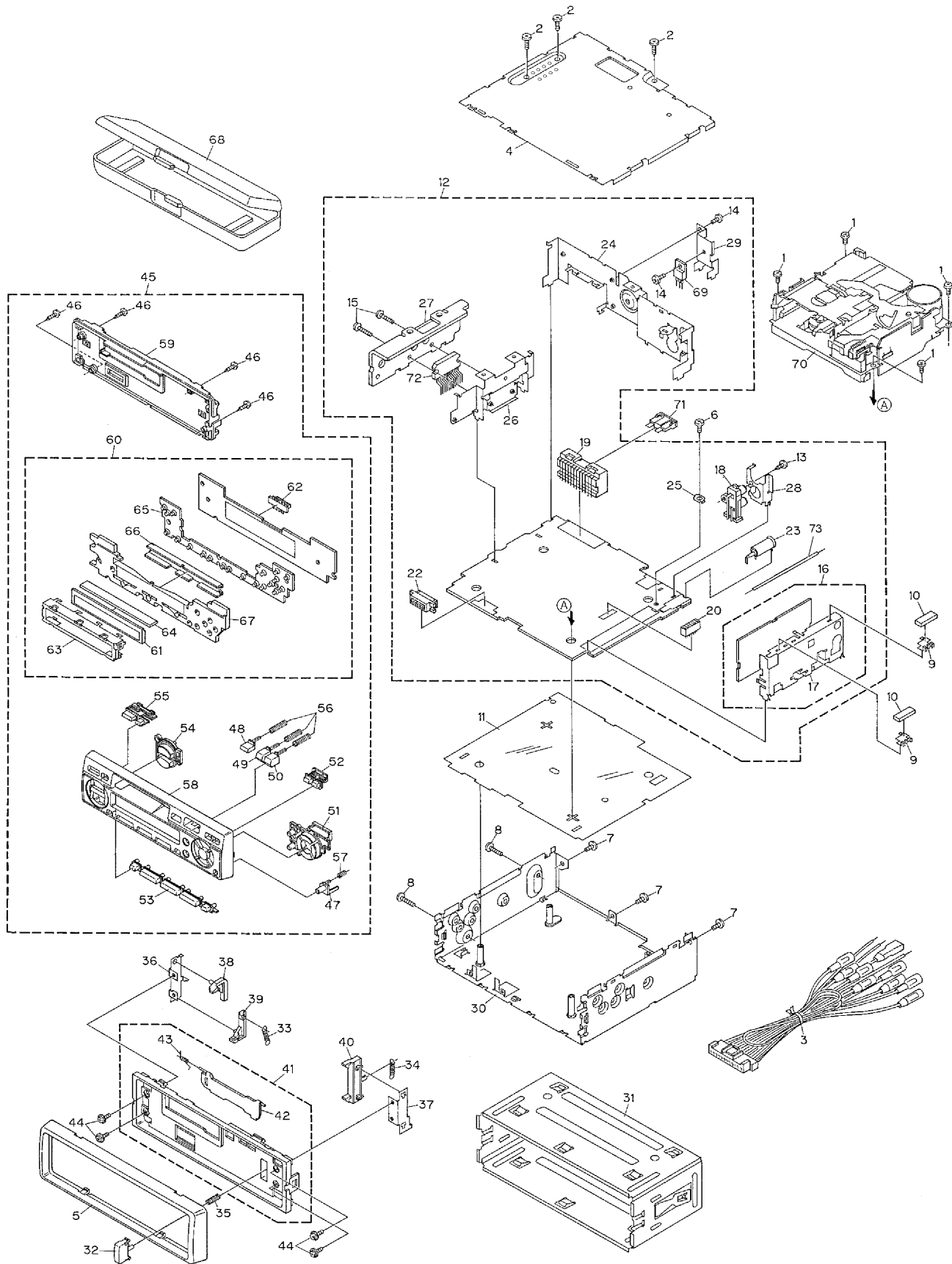

**(1) EXTERIOR SECTION PARTS LIST**

Mark No.	Description	Part No.	Mark No.	Description	Part No.
1	Screw	BSZ26P050FMC	36	Bracket	CNC6135
2	Screw	BSZ30P100FMC	37	Bracket	CNC6791
3	Cord Assy	CDE5805	38	Arm	CNV4692
4	Case	CNB2481	39	Arm	CNV4693
5	Panel	CNS5214	40	Arm	CNV4728
6	Screw	BSZ30P055FUC	41	Panel Unit	CXB3715
7	Screw	BSZ30P060FMC	42	Door	CAT2028
8	Screw	BSZ30P100FMC	43	Spring	CBH1838
9	Holder	CNC5704	44	Screw	IMS20P030FZK
10	Cushion	CNM4870	45	Detach Grille Assy	See Contrast table(2)
11	Insulator	CNM5025	46	Screw	BPZ20P120FZK
12	Tuner Amp Unit	See Contrast table(2)	47	Button(Detachable)	CAC5868
13	Screw	BPZ26P080FMC	48	Button(Eject)	CAC5870
14	Screw	BSZ26P080FMC	49	Button(REW)	CAC5872
15	Screw	BSZ26P140FMC	50	Button(FF)	CAC5874
16	FM/AM Tuner Unit	See Contrast table(2)	51	Button(F,A,Cross)	CAC5876
17	Holder	CNC6554	52	Button(-,-)	CAC5878
18	Pin Jack(CN401)	CKB1035	53	Button(1-6,D,B)	CAC5985
19	Plug(CN601)	CKM1270	54	Button(+,-)	CAC5882
20	Connector(CN604)	CKS3362	55	Button(SO/OFF,PGM)	CAC5884
21	.....		56	Spring	CBH1836
22	Connector(CN603)	CKS3581	57	Spring	CBH2103
23	Antenna Jack(CN301)	CKX1056	58	Grille	See Contrast table(2)
24	Panel	CNB2247	59	Cover	CNS5209
25	Holder	CNC5399	60	Keyboard Unit	CWM6273
26	Holder	CNC6216	61	LCD(LCD901)	CAW1513
27	Heat Sink	CNC6217	62	Connector(CN901)	CKS3580
28	Holder	CNC6531	63	Holder	CNC8054
29	Holder	CNC6845	64	Connector	CNV5586
30	Chassis Unit	CXA9851	65	Rubber	CNV5587
31	Holder Unit	CXB2687	66	Holder	CNV5589
32	Button	CAC4836	67	Lighting Conductor	CNV5752
33	Spring	CBH1834	68	Case Assy	CXB3520
34	Spring	CBH1835	69	Transistor(Q804)	2SD2396
35	Spring	CBH1996	70	Cassette Mechanism Assy	EXK3450
			71	Fuse(FU951)(10A)	CEK1136
			72	IC(IC501)	TDA7384
			* 73	Cord	See Contrast table(2)

**(2) CONTRAST TABLE**

KEH-1800/X1M/UC and KEH-1850/X1M/ES are constructed the same except for the following:

Mark No.	Description	Part No.	
		KEH-1800/X1M/UC	KEH-1850/X1M/ES
12	Tuner Amp Unit	CWM6352	CWM6277
16	FM/AM Tuner Unit	CWE1467	CWE1486
45	Detach Grille Assy	CXB3379	CXB3370
58	Grille	CNS5207	CNS5208
* 73	Cord	CDC1043	Not used

## 2.3 CASSETTE MECHANISM ASSY

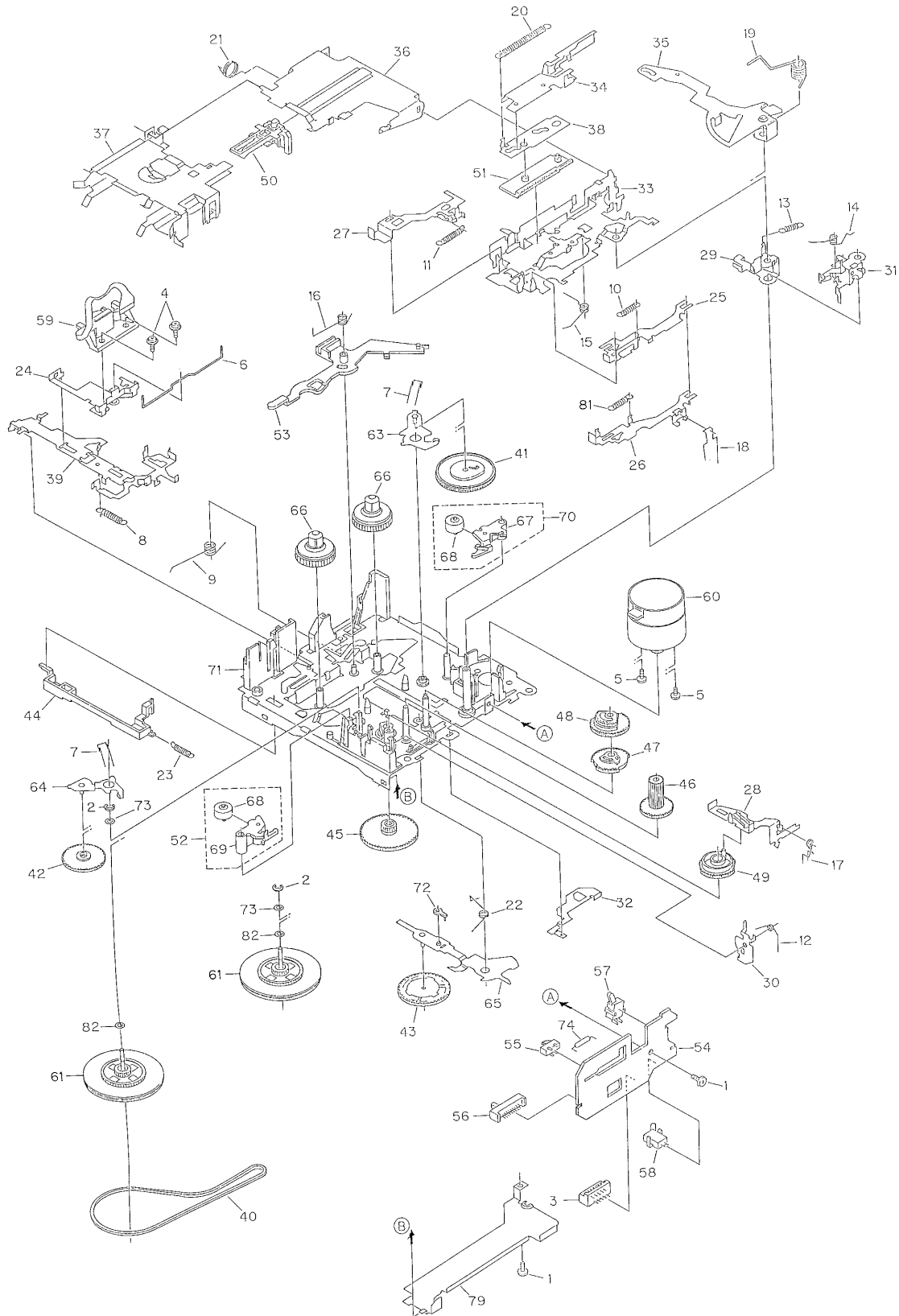

### ● CASSETTE MECHANISM ASSY SECTION PARTS LIST

Mark No.	Description	Part No.	Mark No.	Description	Part No.
1	Screw	BSZ23P050FMC	46	Gear	ENV1475
2	Washer	CBG1003	47	Gear	ENV1512
3	Connector(CN1)	CKS2829	48	Gear	ENV1513
4	Screw(M2x5)	EBA1038	49	Gear	ENV1502
5	Screw(M2x2.5)	EBA1037	50	Lever	ENV1480
6	Spring	EBH1554	51	Lever	ENV1487
7	Spring	EBH1555	52	Pinch Holder Unit	EXA1516
8	Spring	EBH1556	53	Arm	ENV1519
9	Spring	EBH1603	* 54	PCB	ENP1161
10	Spring	EBH1591	55	Switch(Eject)(S4)	ESG1006
11	Spring	EBH1559	56	Switch(FWD)(REV)(S3)	ESH1006
12	Spring	EBH1593	57	Switch(Load)(S1)	ESN1016
13	Spring	EBH1561	58	Switch(Mute)(S2)	ESN1017
14	Spring	EBH1562	59	Head Assy(HD1)	EXA1466
15	Spring	EBH1563	60	Motor Unit(M1)	EXA1467
16	Spring	EBH1590	61	Flywheel Unit	EXA1547
17	Spring	EBH1565	62	.....	
18	Spring	EBH1566	63	Arm Unit	EXA1447
19	Spring	EBH1567	64	Arm Unit	EXA1448
20	Spring	EBH1568	65	Arm Unit	EXA1550
21	Spring	EBH1569	66	Reel Unit	EXA1450
22	Spring	EBH1571	67	Pinch Holder	ENV1466
23	Spring	EBH1579	68	Pinch Roller	ENV1518
24	Head Base	ENC1475	69	Pinch Holder	ENV1467
25	Lever	ENC1429	70	Pinch Holder Unit	EXA1515
26	Lever	ENC1430	71	Chassis Unit	EXA1498
27	Lever	ENC1431	72	Arm	ENV1524
28	Lever	ENC1432	73	Washer	CBF-167
29	Arm	ENC1433	74	Resistor(R1)	RD1/4HM472J
30	Arm	ENC1434	75-78	.....	
31	Arm	ENC1480	79	Cover	ENC1452
32	Arm	ENC1476	80	.....	
33	Bracket	ENC1512	81	Spring	EBH1592
34	Lever	ENC1523	82	Washer	CBF1051
35	Arm	ENC1524			
36	Frame	ENC1440			
37	Holder	ENC1441			
38	Lever	ENC1446			
39	Lever	ENC1478			
40	Belt	ENT1027			
41	Gear	ENV1504			
42	Gear	ENV1470			
43	Gear	ENV1517			
44	Lever	ENV1472			
45	Gear	ENV1510			

### 3. SCHEMATIC DIAGRAM

#### 3.1 OVERALL CONNECTION DIAGRAM(GUIDE PAGE)

Note: When ordering service parts, be sure to refer to "EXPLODED VIEWS AND PARTS LIST" or "ELECTRICAL PARTS LIST".

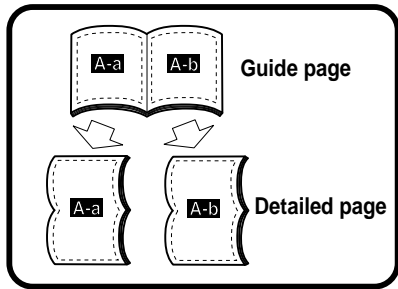
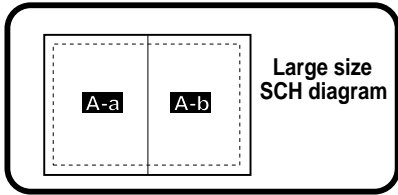

# A-a

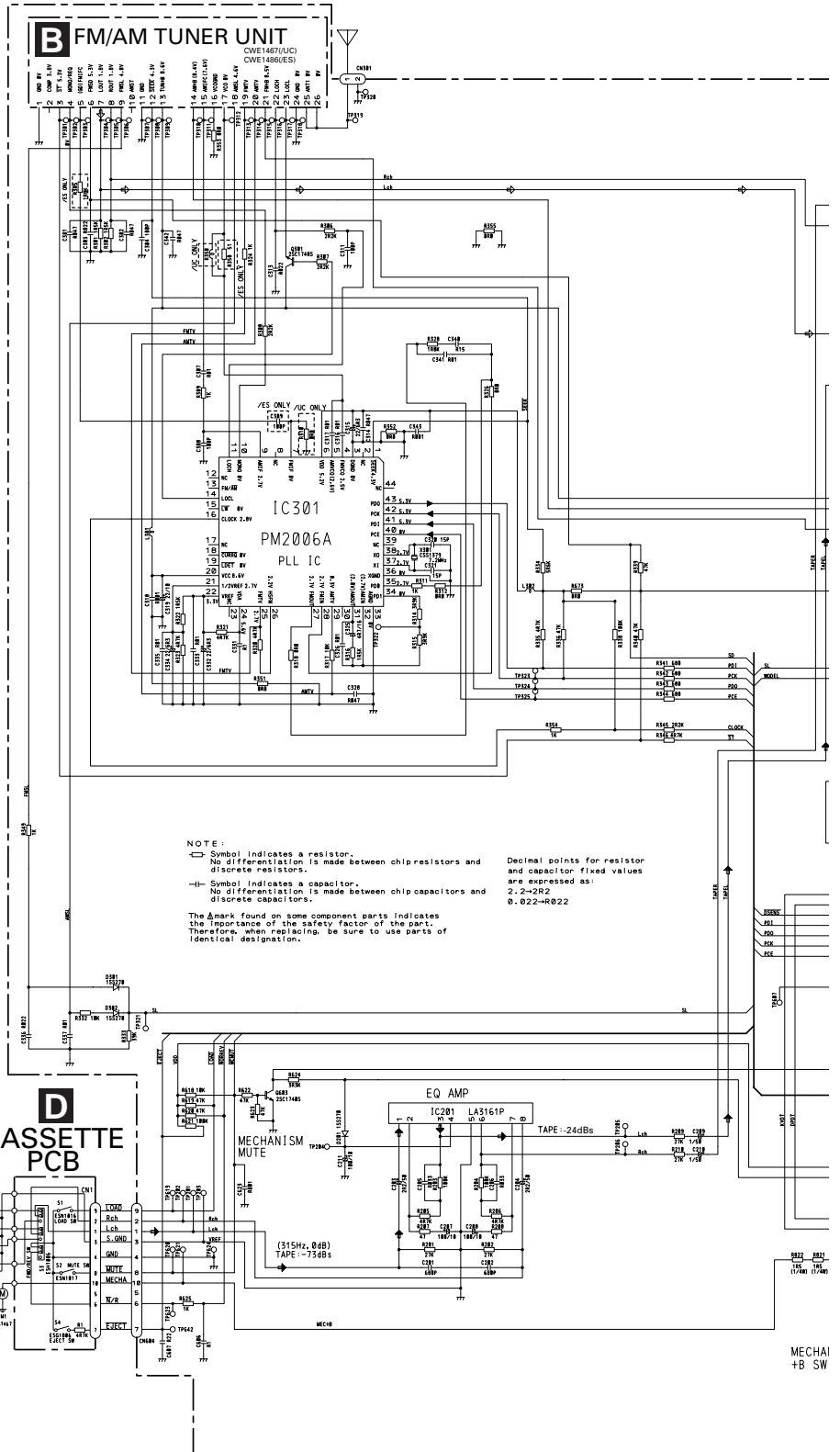



# A-b

## A TUNER AMP UNIT

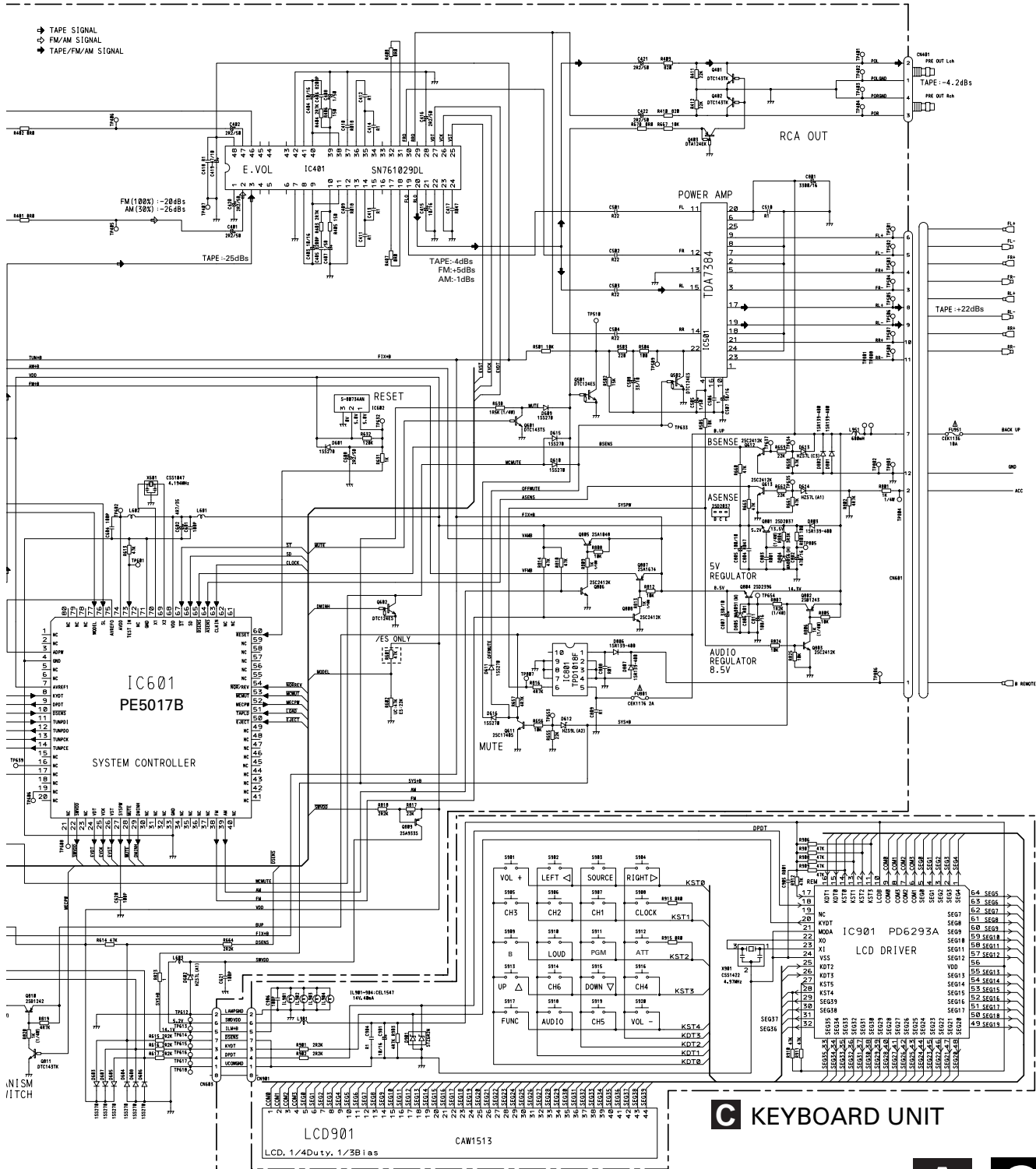

## C KEYBOARD UNIT

# A C

A-a A-b

A

B

C

D

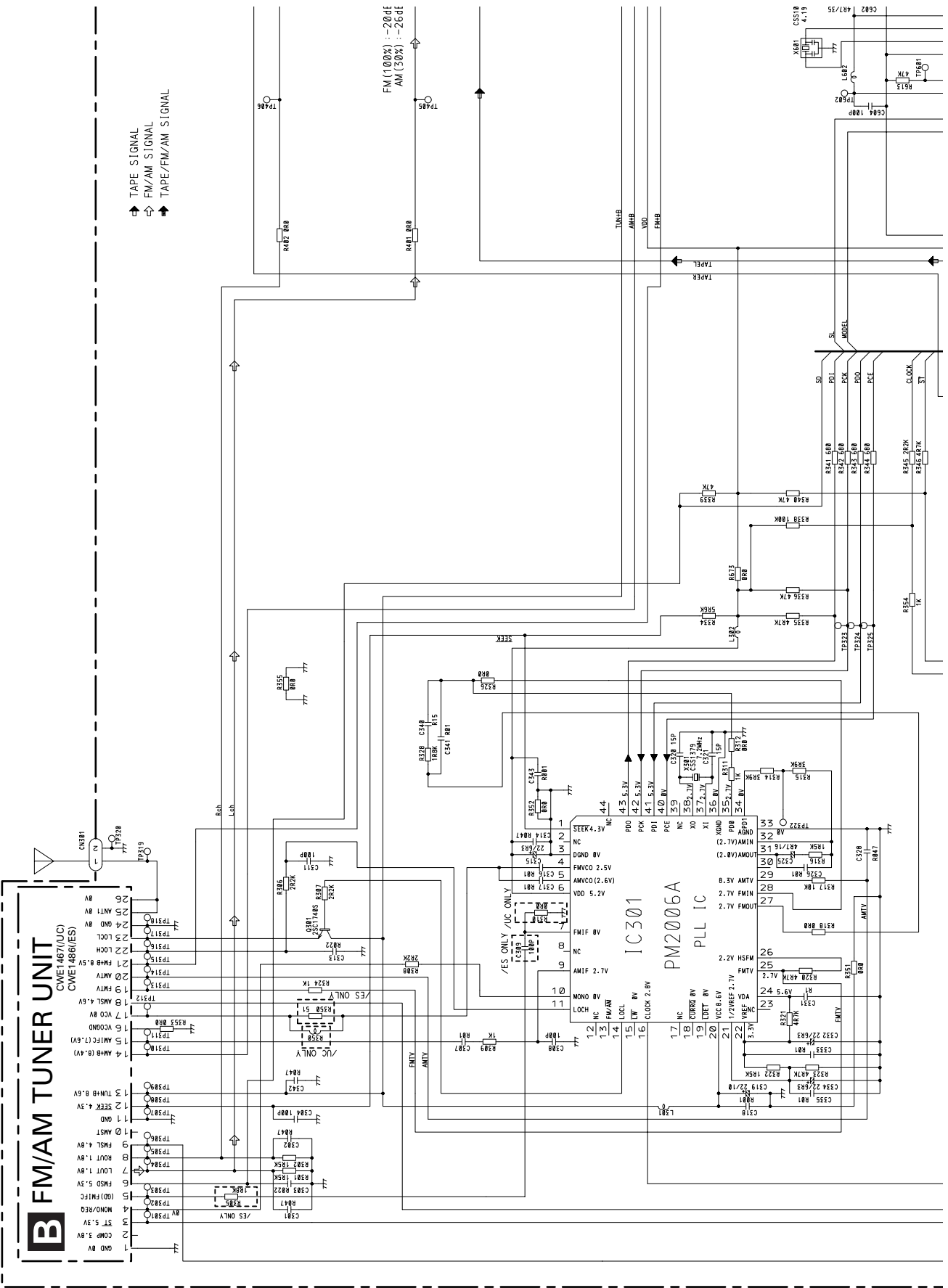

A-a

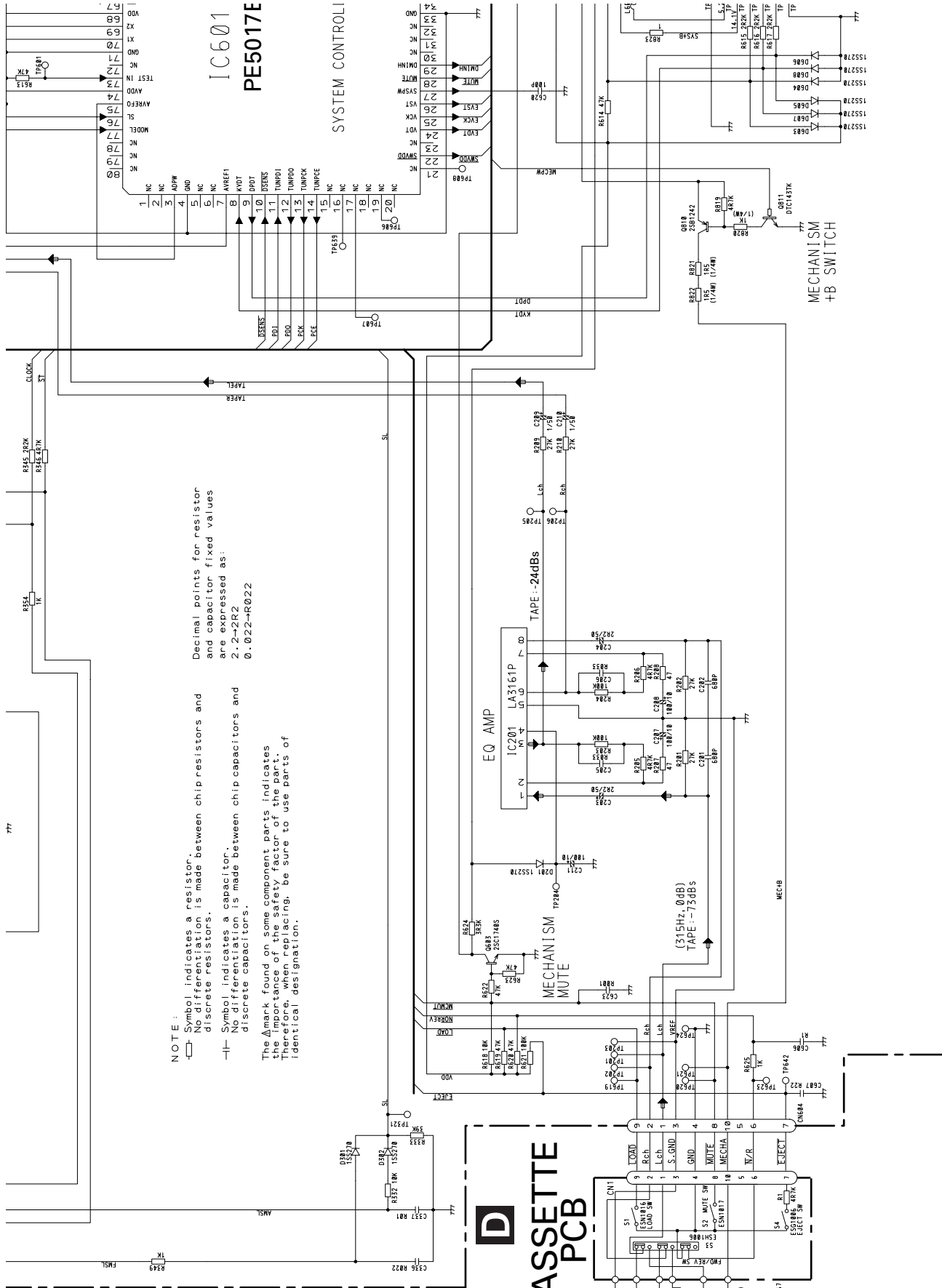

NOTE :  
 □ Symbol indicates a resistor.  
 No differentiation is made between chip resistors and discrete resistors.  
 —|— Symbol indicates a capacitor.  
 No differentiation is made between chip capacitors and discrete capacitors.  
 The Δ mark found on some component parts indicates the importance of the safety factor of the part. Therefore, when replacing, be sure to use parts of identical designation.

Decimal points for resistor and capacitor fixed values are expressed as:  
 2.2-2R2  
 0.022-R022

A-a A-b

A  
B  
C  
D

A-a D

# A TUNER AMP UNIT

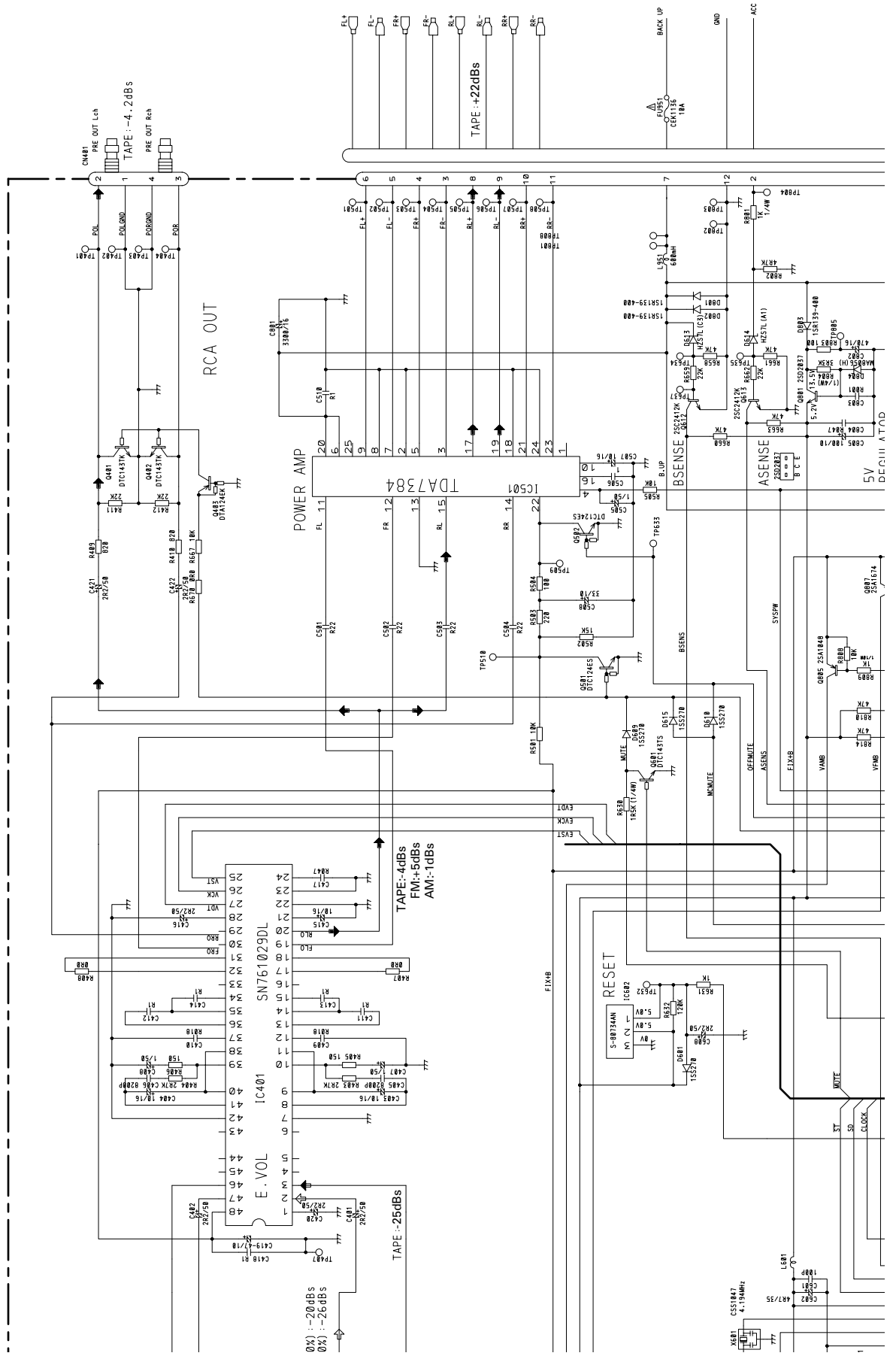

A

B

C

D

1

2

3

4

2

3

4

A-a A-b

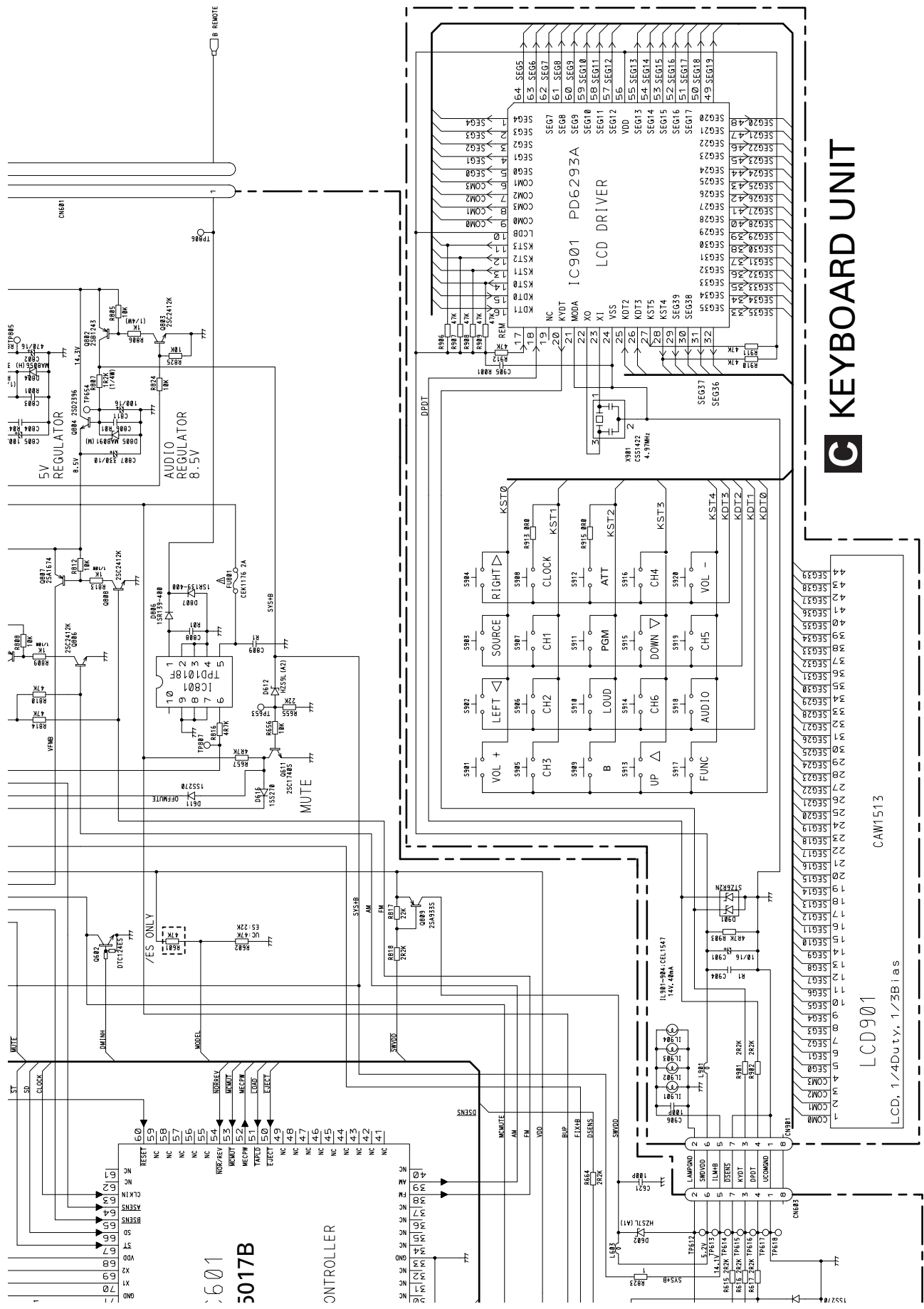

A-b C

### 3.2 FM/AM TUNER UNIT

● CWE1467 (KEH-1800/X1M/UC)

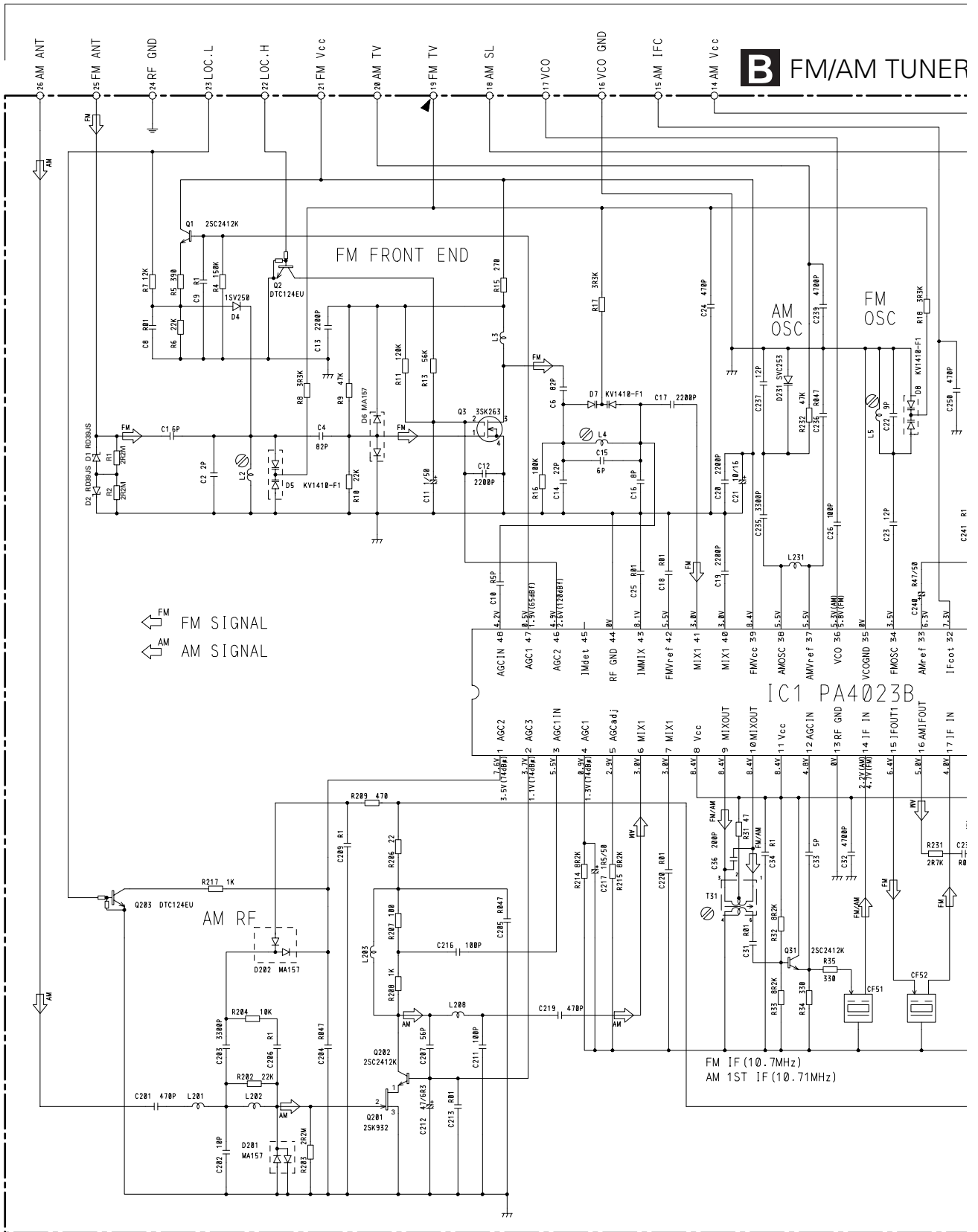

**B** FM/AM TUNER

**B**



● CWE1486 (KEH-1850/X1M/ES)

**B** FM/AM TUNER

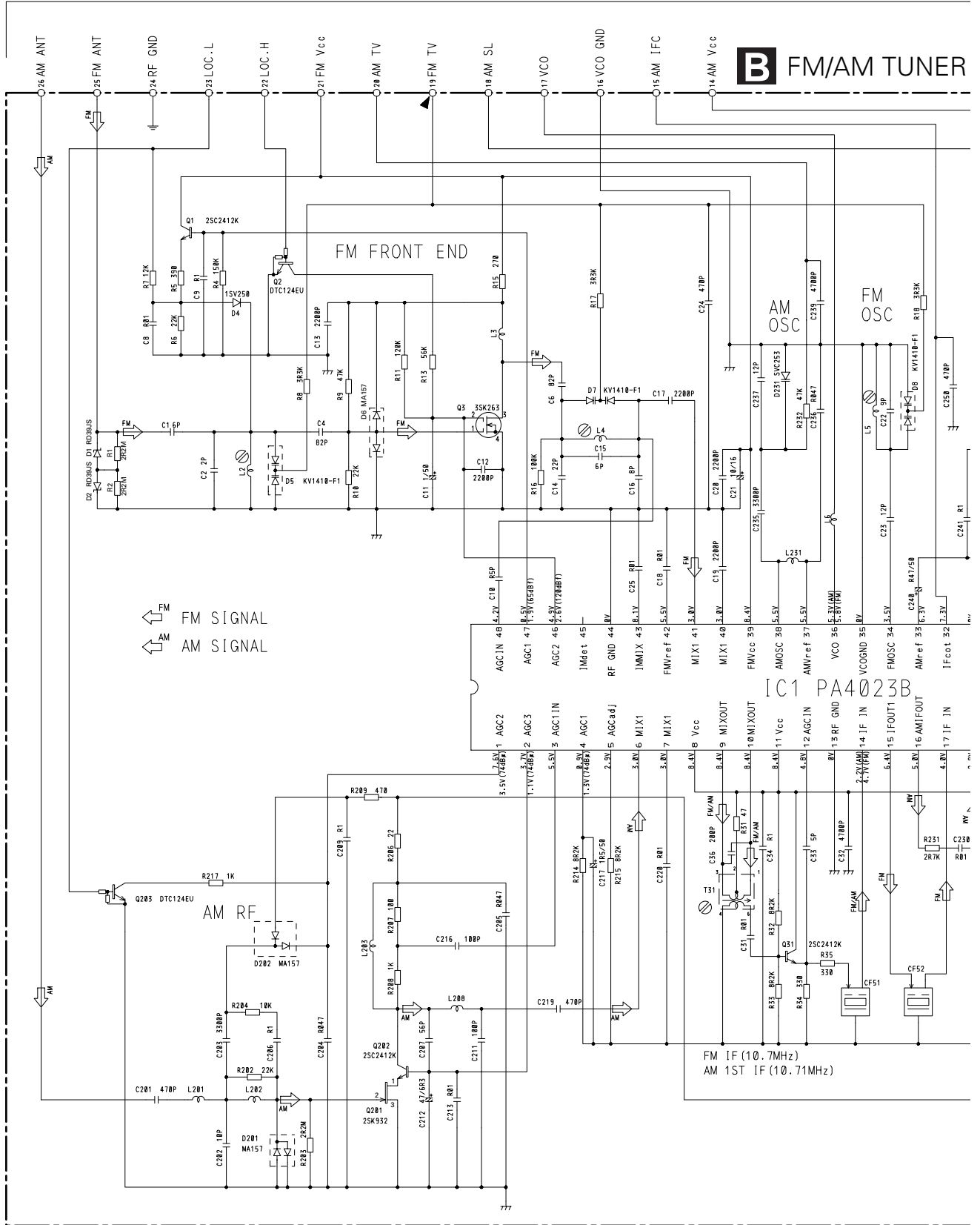





# 4. PCB CONNECTION DIAGRAM

## 4.1 TUNER AMP UNIT

### NOTE FOR PCB DIAGRAMS

- The parts mounted on this PCB include all necessary parts for several destination. For further information for respective destinations, be sure to check with the schematic diagram.
- Viewpoint of PCB diagrams

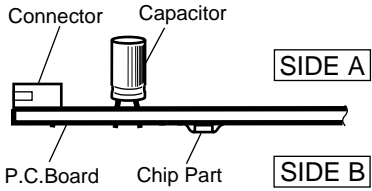

### A TUNER AMP UNIT

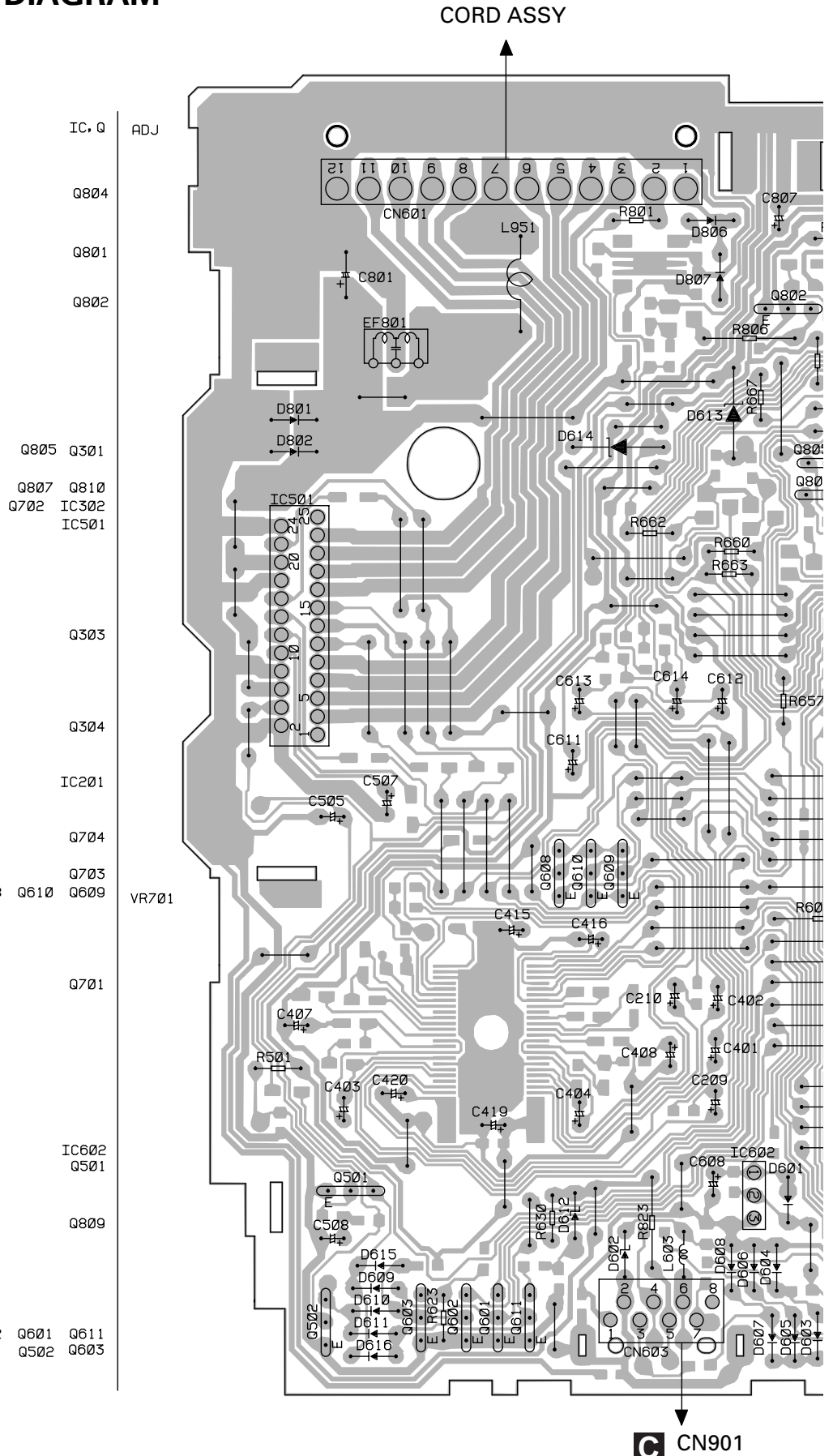

SIDE A

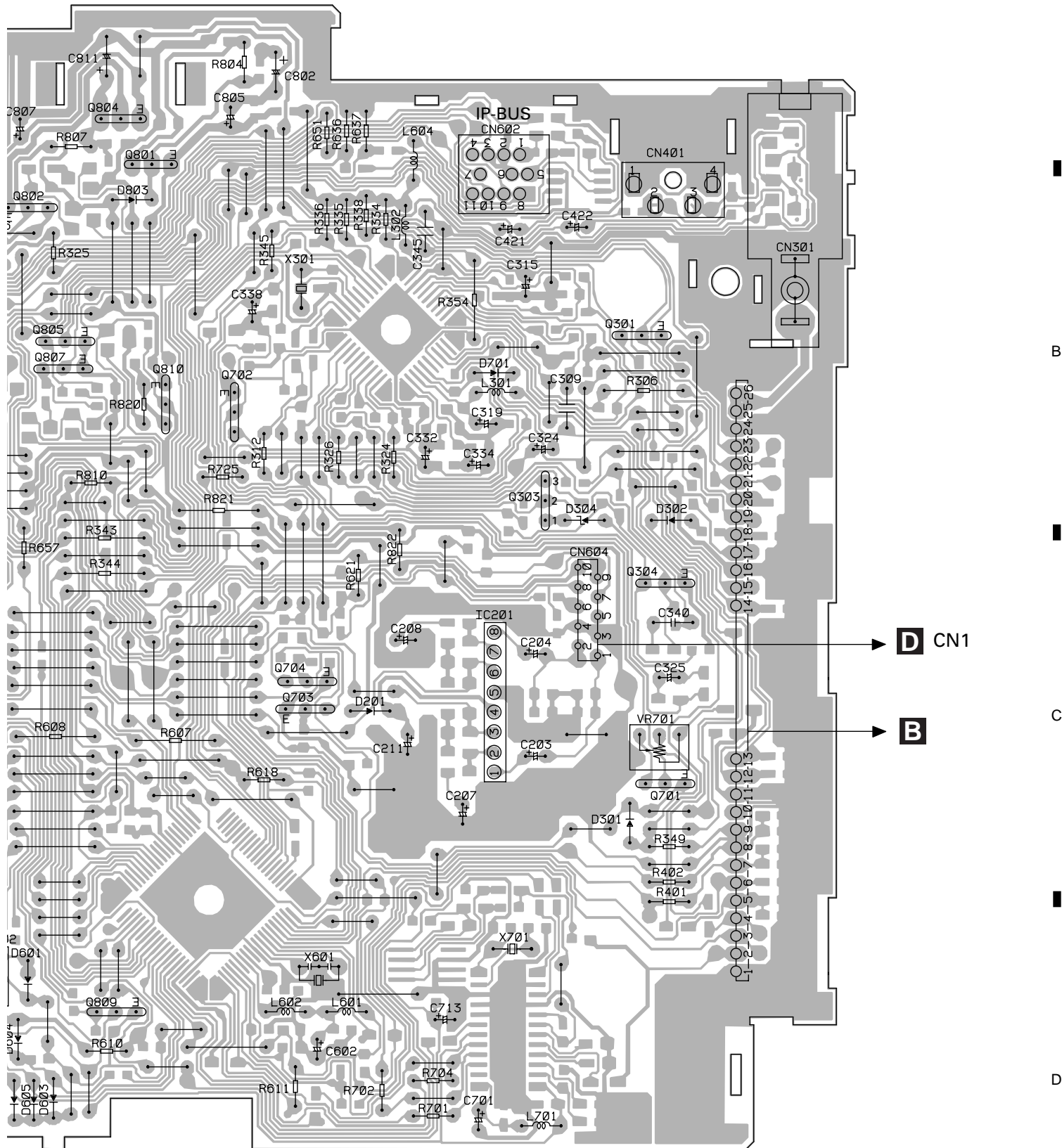

D CN1

B

A

**A** TUNER AMP UNIT

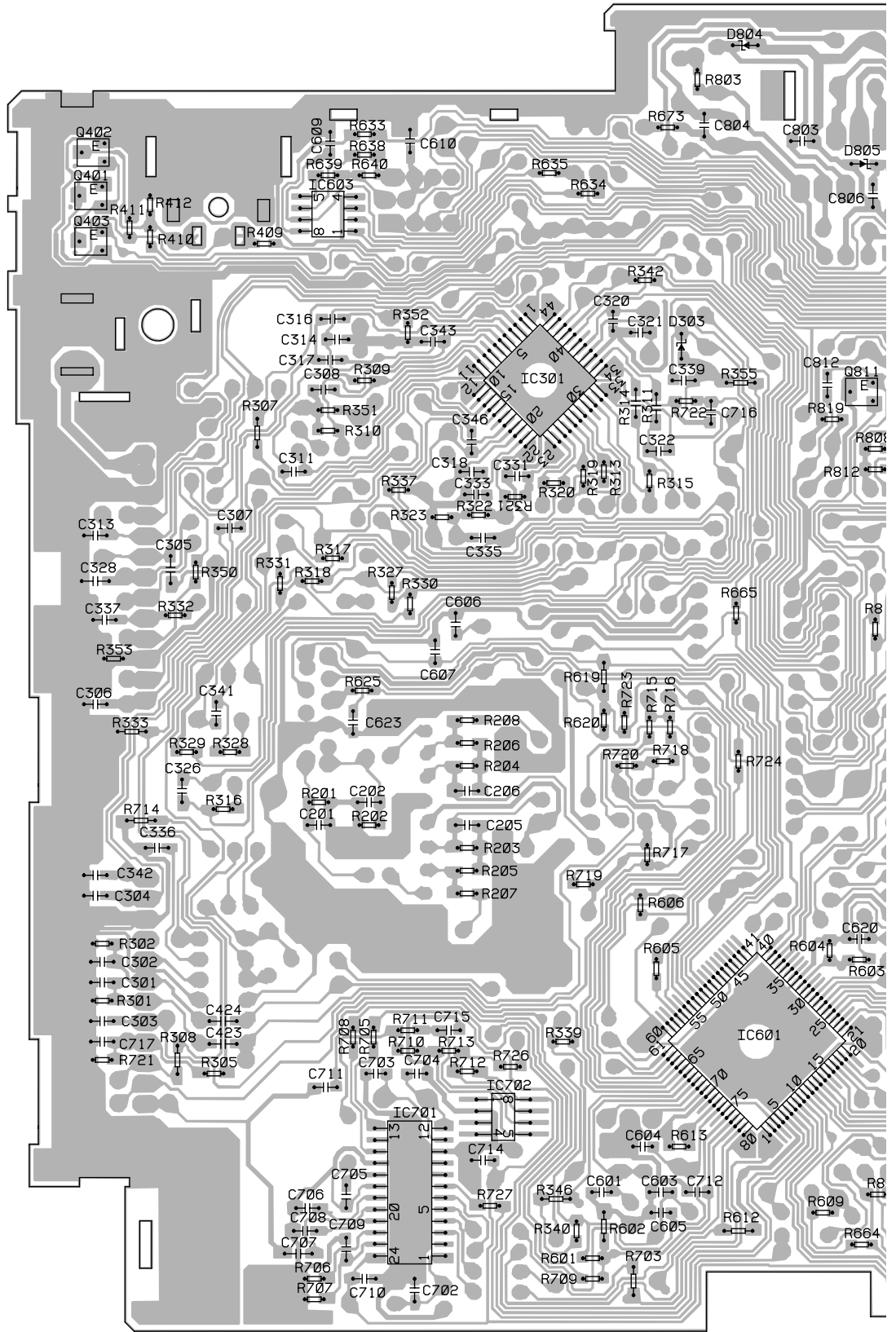



### 4.2 FM/AM TUNER UNIT

SIDE A

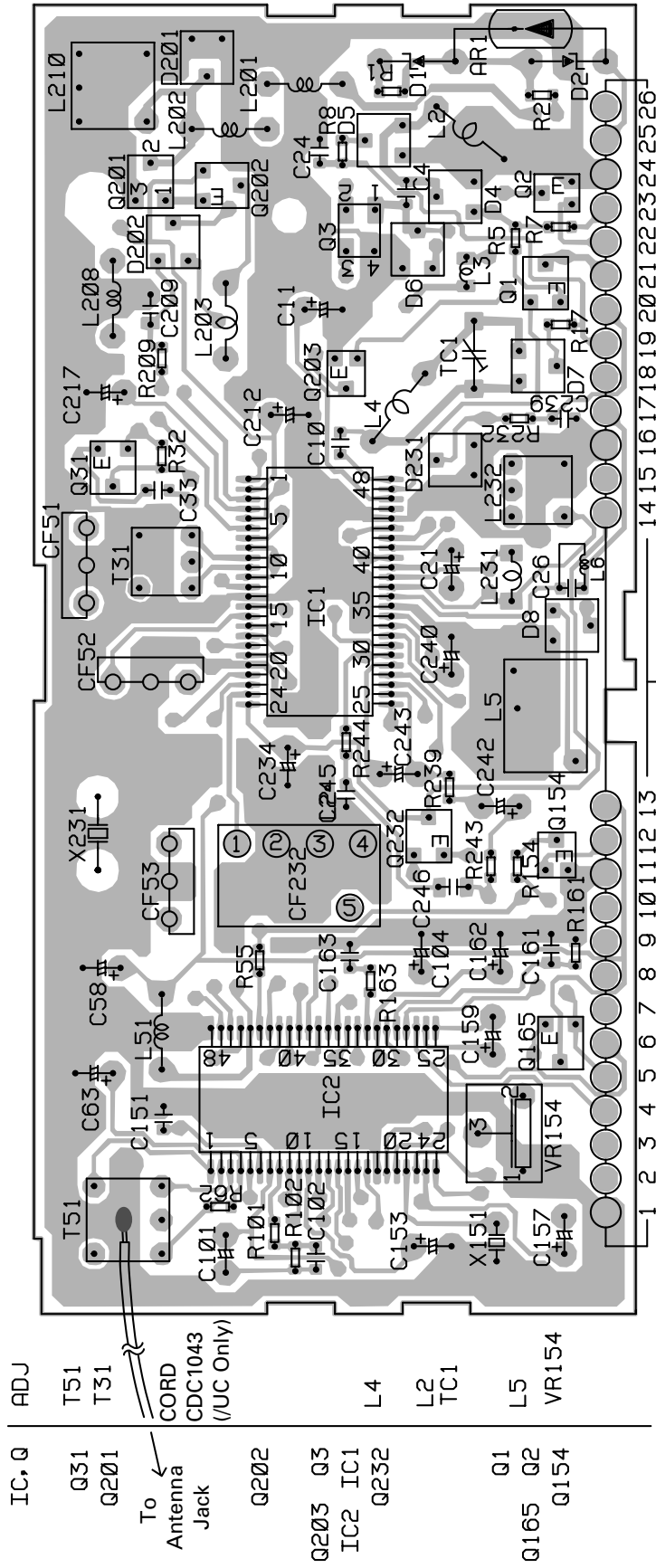

B FM/AM TUNER UNIT

- IC, Q
- ADJ
- T51
- T31
- CORD
- CDC1043
- (/UC Only)
- L4
- L2
- TC1
- L5
- VR154
- Q1
- Q2
- Q154
- Q200
- Q3
- IC1
- Q232
- Q165
- Q154





SIDE B

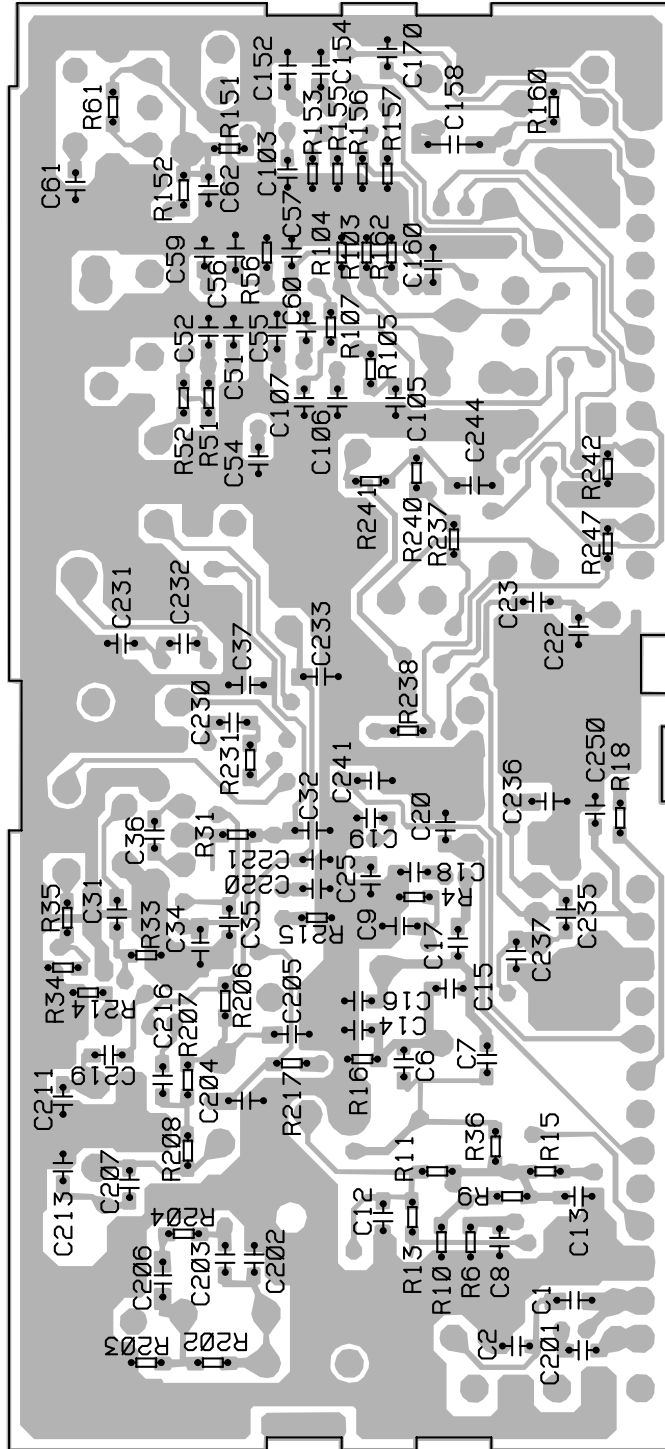

B FM/AM TUNER UNIT

### 4.3 KEYBOARD UNIT

SIDE A

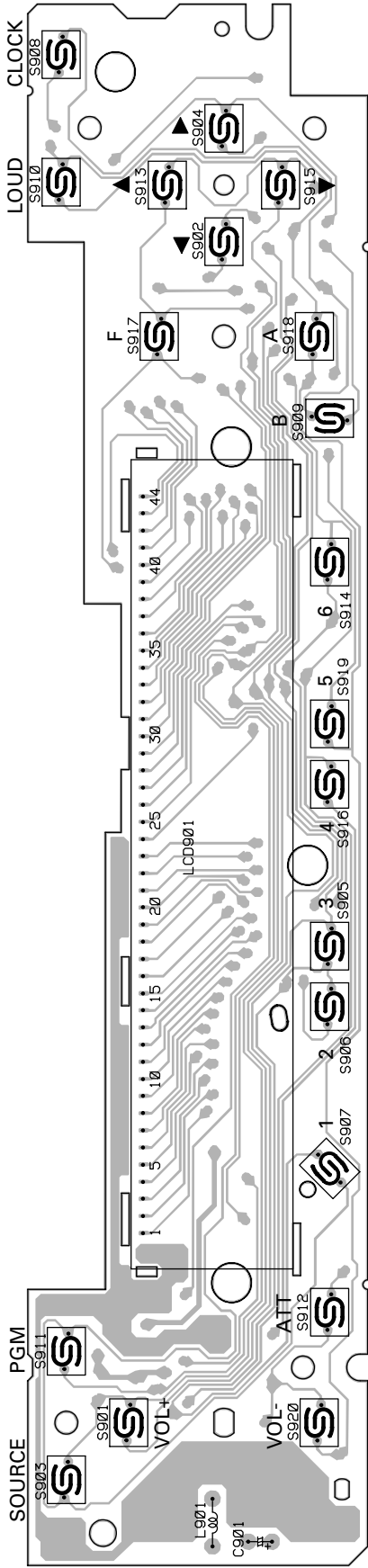

C KEYBOARD UNIT

SIDE B

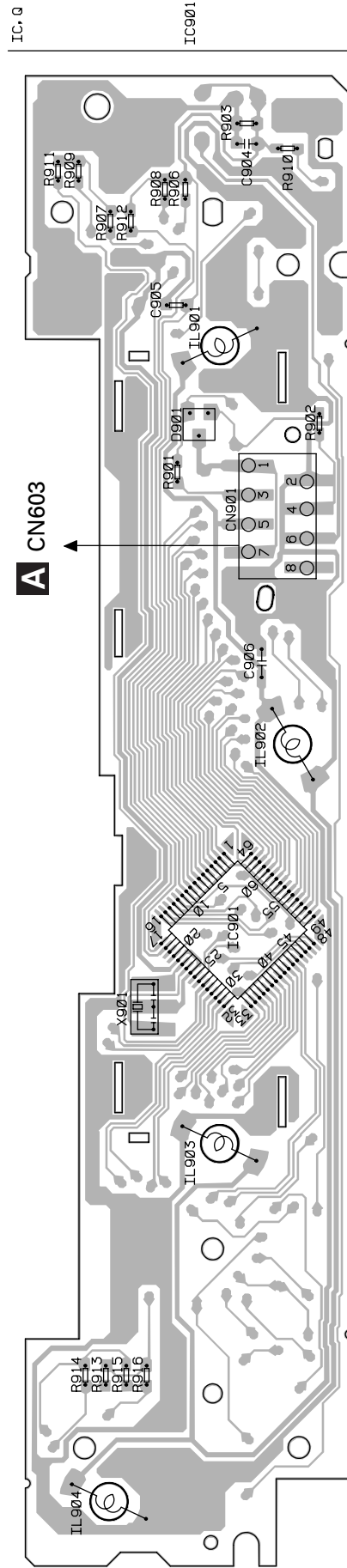

C KEYBOARD UNIT



### 4.4 CASSETTE MECHANISM ASSY

#### **D** CASSETTE PCB

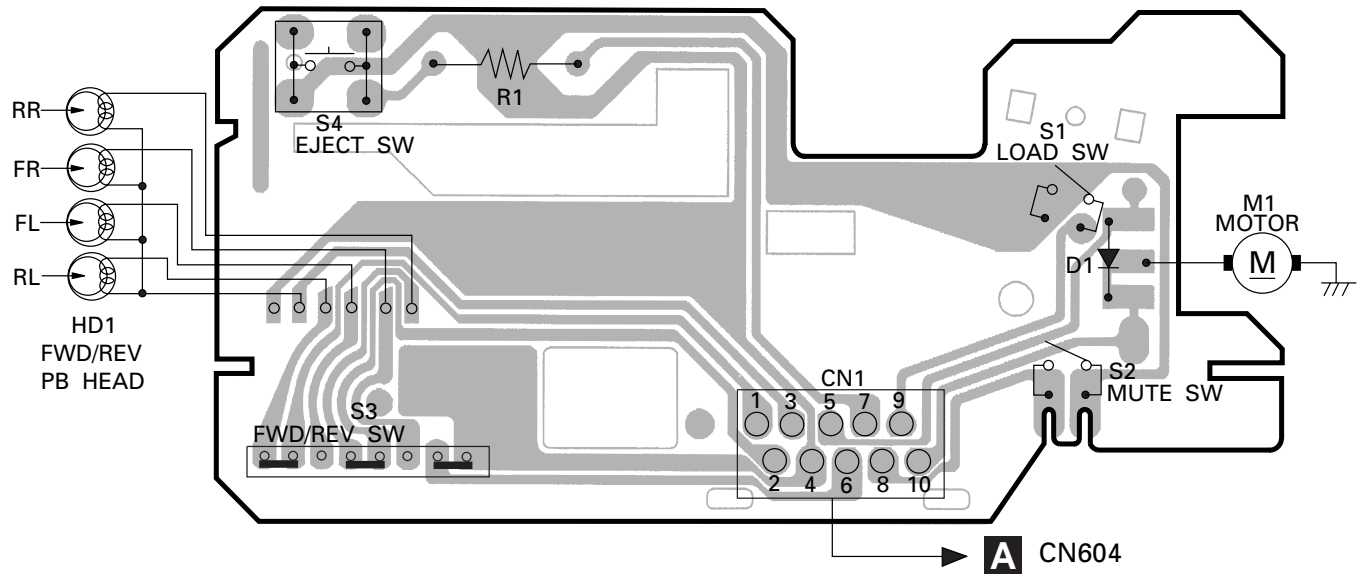

## 5. ELECTRICAL PARTS LIST

### NOTE:

- Parts whose parts numbers are omitted are subject to being not supplied.
- The part numbers shown below indicate chip components.

Chip Resistor

RS1/○S○○○○J,RS1/○○S○○○J

Chip Capacitor (except for CQS.....)

CKS....., CCS....., CSZS.....

====Circuit Symbol and No.====Part Name	Part No.	====Circuit Symbol and No.====Part Name	Part No.
<b>A</b> Unit Number : CWM6352(KEH-1800/X1M/UC)		D 802 Diode	1SR139-400
Unit Number : CWM6277(KEH-1850/X1M/ES)		D 803 Diode	1SR139-400
Unit Name : Tuner Amp Unit		D 804 Diode	MA8056(H)
		D 805 Diode	MA8091(M)
		D 806 Diode	1SR139-400
MISCELLANEOUS		D 807 Diode	1SR139-400
IC 201 IC	LA3161P	L 301 Ferri-Inductor	LAU101K
IC 301 IC	PM2006A	L 302 Ferri-Inductor	LAU2R2K
IC 401 IC	SN761029DL	L 601 Ferri-Inductor	LAU101K
IC 501 IC	TDA7384	L 602 Ferri-Inductor	LAU101K
IC 601 IC	PE5017B		
IC 602 IC	S-80734AN	L 603 Ferri-Inductor	LAU101K
IC 801 IC	TPD1018F	L 951 Choke Coil 600mH	CTH1168
Q 301 Transistor	2SC1740S	X 301 Crystal Resonator 7.200MHz	CSS1379
Q 401 Transistor	DTC143TK	X 601 Ceramic Resonator 4.194MHz	CSS1047
Q 402 Transistor	DTC143TK	FU 801 Fuse 2A	CEK1176
Q 403 Transistor	DTA124EK		FM/AM Tuner Unit(KEH-1800/X1M/UC) CWE1467
Q 501 Transistor	DTC124ES		FM/AM Tuner Unit(KEH-1850/X1M/ES) CWE1486
Q 502 Transistor	DTC124ES		
Q 601 Transistor	DTC143TS		
Q 602 Transistor	DTC124ES		
		RESISTORS	
Q 603 Transistor	2SC1740S	R 201	RS1/10S273J
Q 611 Transistor	2SC1740S	R 202	RS1/10S273J
Q 612 Transistor	2SC2412K	R 203	RS1/10S104J
Q 613 Transistor	2SC2412K	R 204	RS1/10S104J
Q 801 Transistor	2SD2037	R 205	RS1/10S472J
Q 802 Transistor	2SB1243	R 206	RS1/10S472J
Q 803 Transistor	2SC2412K	R 207	RS1/10S470J
Q 804 Transistor	2SD2396	R 208	RS1/10S470J
Q 805 Transistor	2SA1048	R 209	RS1/10S273J
Q 806 Transistor	2SC2412K	R 210	RS1/10S273J
Q 807 Transistor	2SA1674	R 301	RS1/10S152J
Q 808 Transistor	2SC2412K	R 302	RS1/10S152J
Q 809 Transistor	2SA933S	R 305 (KEH-1850/X1M/ES)	RS1/10S182J
Q 810 Transistor	2SB1242	R 306	RD1/4PU222J
Q 811 Transistor	DTC143TK	R 307	RS1/8S222J
D 201 Diode	1SS270	R 308	RS1/8S222J
D 301 Diode	1SS270	R 309	RS1/10S102J
D 302 Diode	1SS270	R 310 (KEH-1800/X1M/UC)	RS1/10S0R0J
D 601 Diode	1SS270	R 311	RS1/8S102J
D 602 Diode	HZS7L(A1)	R 312	RD1/4PU0R0J
D 603 Diode	1SS270	R 314	RS1/8S392J
D 604 Diode	1SS270	R 315	RS1/10S392J
D 605 Diode	1SS270	R 316	RS1/10S152J
D 606 Diode	1SS270	R 317	RS1/10S103J
D 607 Diode	1SS270	R 318	RS1/10S0R0J
D 608 Diode	1SS270	R 320	RS1/10S472J
D 609 Diode	1SS270	R 321	RS1/10S472J
D 610 Diode	1SS270	R 322	RS1/10S152J
D 611 Diode	1SS270	R 323	RS1/10S472J
D 612 Diode	HZS9L(A2)	R 324	RD1/4PU102J
D 613 Diode	HZS7L(C3)	R 326	RD1/4PU0R0J
D 614 Diode	HZS7L(A1)	R 328	RS1/10S182J
D 615 Diode	1SS270	R 332	RS1/10S103J
D 616 Diode	1SS270	R 333	RS1/8S393J
D 801 Diode	1SR139-400	R 334	RD1/4PU562J



====Circuit Symbol and No.====	Part Name	Part No.
C 342		CKSQYB473K50
C 343		CKSQYB102K50
C 401		CEJA2R2M50
C 402		CEJA2R2M50
C 403		CEJA100M16
C 404		CEJA100M16
C 405		CKSQYB822K50
C 406		CKSQYB822K50
C 407		CEJA1R0M50
C 408		CEJA1R0M50
C 409		CKSQYB183K50
C 410		CKSQYB183K50
C 411		CKSQYB104K16
C 412		CKSQYB104K16
C 413		CKSQYB104K16
C 414		CKSQYB104K16
C 415		CEJA100M16
C 416		CEJA2R2M50
C 417		CKSQYB473K50
C 418		CKSQYB104K16
C 419		CEJA470M10
C 420		CEJA2R2M50
C 421		CEJA2R2M50
C 422		CEJA2R2M50
C 501		CKSYB224K16
C 502		CKSYB224K16
C 503		CKSYB224K16
C 504		CKSYB224K16
C 505		CEJA1R0M50
C 506		CKSYB105K16
C 507		CEJA100M16
C 508		CEJA330M10
C 510		CKSQYB104K16
C 601		CCSQCH101J50
C 602		CEJA4R7M35
C 604		CCSQCH101J50
C 606		CKSQYB104K16
C 607		CKSQYB224K16
C 608		CEJA2R2M50
C 620		CCSQCH101J50
C 621		CCSQCH101J50
C 623		CKSQYB102K50
C 801	3300µF/16V	CCH1018
C 802	470µF/16V	CCH1183
C 803		CKSQYB102K50
C 804		CKSQYB473K50
C 805		CEJA101M10
C 806		CKSQYB103K50
C 807	330µF/10V	CCH1181
C 808		CKSQYB103K50
C 809		CKSQYB104K16
C 811	100µF/16V	CCH1179

**C** Unit Number : CWM6273  
Unit Name : Keyboard Unit

MISCELLANEOUS

IC 901	IC	PD6293A
D 901	Diode	STZ6R2N
L 901	Ferri-Inductor	LAU101K
X 901	Ceramic Resonator 4.97MHz	CSS1422
IL 901	Lamp 14V 40mA	CEL1547
IL 902	Lamp 14V 40mA	CEL1547
IL 903	Lamp 14V 40mA	CEL1547
IL 904	Lamp 14V 40mA	CEL1547
LCD 901	LCD	CAW1513

====Circuit Symbol and No.====	Part Name	Part No.
--------------------------------	-----------	----------

RESISTORS

R 901		RS1/10S222J
R 902		RS1/10S222J
R 903		RS1/10S472J
R 906		RS1/10S473J
R 907		RS1/10S473J
R 908		RS1/10S473J
R 909		RS1/10S473J
R 910		RS1/10S473J
R 911		RS1/10S473J
R 912		RS1/10S473J
R 913		RS1/10S0R0J
R 915		RS1/10S0R0J

CAPACITORS

C 901		CEAL100M16
C 904		CKSQYB104K16
C 905		CKSQYB102K50
C 906		CCSCH101J50

**B** Unit Number : CWE1467 (KEH-1800/X1M/UC)  
Unit Name : FM/AM Tuner Unit

MISCELLANEOUS

IC 1	IC	PA4023B
IC 2	IC	PA4024A
Q 1	Transistor	2SC2412K
Q 2	Transistor	DTC124EU
Q 3	FET	3SK263
Q 31	Transistor	2SC2412K
Q 201	FET	2SK932
Q 202	Transistor	2SC2412K
Q 203	Transistor	DTC124EU
D 1	Diode	RD39JS
D 2	Diode	RD39JS
D 4	Diode	1SV250
D 5	Diode	KV1410-F1
D 6	Diode	MA157
D 7	Diode	KV1410-F1
D 8	Diode	KV1410-F1
D 201	Diode	MA157
D 202	Diode	MA157
D 231	Diode	SVC253
L 2	Coil	CTC1133
L 3	Inductor	LCTB2R2K2125
L 4	Coil	CTC1133
L 5	Coil	CTC1132
L 51	Ferri-Inductor	LAU150K
L 201	Ferri-Inductor	LAU4R7K
L 202	Ferri-Inductor	LAU330K
L 203	Inductor	CTF1287
L 208	Inductor	LAU121K
L 231	Inductor	LCTA3R3J3225
T 31	Coil	CTE1117
T 51	Coil	CTC1159
CF 51	Ceramic Filter	CTF1441
CF 52	Ceramic Filter	CTF1441
CF 53	Ceramic Filter	CTF1441
CF 232	Ceramic Filter	CTF1348
X 151	Radiator 918.5Hz	CSS1365
X 231	Crystal Resonator 10.26MHz	CSS1111
VR 154	Semi-fixed 150kΩ(B)	CCP1213

====Circuit Symbol and No.====Part Name	Part No.	====Circuit Symbol and No.====Part Name	Part No.
<b>RESISTORS</b>		<b>CAPACITORS</b>	
R 1	RS1/16S225J	C 1	CCSQCH6R0D50
R 2	RS1/16S225J	C 2	CCSRCK2R0C50
R 4	RS1/16S154J	C 4	CCSRCH820J50
R 5	RS1/16S391J	C 6	CCSRCH820J50
R 6	RS1/16S223J	C 8	CKSRYB103K25
R 7	RS1/16S123J	C 9	CKSQYB104K16
R 8	RS1/16S332J	C 10	CCSRCKR50C50
R 9	RS1/16S473J	C 11	CEJA1R0M50
R 10	RS1/16S223J	C 12	CKSRYB222K50
R 11	RS1/16S124J	C 13	CKSRYB222K50
R 13	RS1/16S563J	C 14	CCSRCH220J50
R 15	RS1/16S271J	C 15	CCSRCH6R0D50
R 16	RS1/16S104J	C 16	CCSRCH8R0D50
R 17	RS1/16S332J	C 17	CKSRYB222K50
R 18	RS1/16S332J	C 18	CKSRYB103K25
R 31	RS1/16S470J	C 19	CKSRYB222K50
R 32	RS1/16S822J	C 20	CKSRYB222K50
R 33	RS1/16S822J	C 21	CEJA100M16
R 34	RS1/16S331J	C 22	CCSRTH9R0D50
R 35	RS1/16S331J	C 23	CCSRTH120J50
R 51	RS1/16S271J	C 24	CCSRCH471J50
R 52	RS1/16S560J	C 25	CKSRYB103K25
R 55	RS1/16S102J	C 26	CCSRCH101J50
R 56	RS1/16S823J	C 31	CKSRYB103K25
R 61	RS1/16S392J	C 32	CKSQYB472K50
R 62	RS1/16S273J	C 33	CCSRCH5R0C50
R 101	RS1/16S272J	C 34	CKSQYB104K16
R 102	RS1/16S682J	C 36	CCSRRH201J50
R 103	RS1/16S333J	C 51	CKSRYB223K25
R 104	RS1/16S334J	C 52	CKSRYB103K25
R 105	RS1/16S683J	C 54	CCSRCH470J50
R 107	RS1/16S222J	C 55	CKSQYB223K25
R 151	RS1/16S222J	C 56	CKSQYB104K16
R 152	RS1/16S393J	C 57	CKSRYB472K50
R 155	RS1/16S273J	C 58	CEJA330M10
R 156	RS1/16S243J	C 59	CKSRYB103K25
R 157	RS1/16S203J	C 60	CKSRYB102K50
R 160	RS1/16S222J	C 61	CCSRCH270J50
R 161	RS1/16S563J	C 62	CKSRYB103K25
R 162	RS1/16S105J	C 63	CEJAR22M50
R 163	RS1/16S223J	C 101	CEJANP100M10
R 202	RS1/16S223J	C 102	CKSRYB182K50
R 203	RS1/16S225J	C 103	CKSRYB682K25
R 204	RS1/16S103J	C 104	CEJA2R2M50
R 206	RS1/16S220J	C 105	CKSRYB103K25
R 207	RS1/16S101J		
R 208	RS1/16S102J	C 106	CCSRCH151J50
R 209	RS1/16S471J	C 107	CKSRYB103K25
R 214	RS1/16S822J	C 151	CKSRYB472K50
R 215	RS1/16S822J	C 152	CKSQYB104K16
		C 153	CEJA3R3M50
R 217	RS1/16S102J		
R 231	RS1/16S272J	C 154	CKSQYB104K16
R 232	RS1/16S473J	C 157	CEJA3R3M50
R 237	RS1/16S103J	C 158	CKSYB474K16
R 238	RS1/16S104J	C 159	CEJA220M6R3
		C 160	CKSQYB104K16
R 239	RS1/16S104J		
R 240	RS1/16S332J	C 161	CKSQYB104K16
R 241	RS1/16S202J	C 162	CEJA3R3M50
R 243	RS1/16S183J	C 163	CKSRYB102K50
R 244	RS1/16S392J	C 170	CCSRCH100D50
		C 201	CCSRCH471J50
R 247	RS1/16S123J		
		C 202	CCSRCH100D50
		C 203	CKSRYB332K50
		C 204	CKSQYB473K16
		C 205	CKSQYB473K16
		C 206	CKSQYB104K16

# KEH-1800,1850

====Circuit Symbol and No.====Part Name	Part No.	====Circuit Symbol and No.====Part Name	Part No.
C 207	CCSRCH560J50	CF 232	Ceramic Filter
C 209	CKSQYB104K16	X 151	Radiator 918.5Hz
C 211	CCSRCH101J50	X 231	Crystal Resonator 10.26MHz
C 212	CEJA470M6R3	VR 154	Semi-fixed 150kΩ(B)
C 213	CKSRYP103K25		
C 216	CCSRCH101J50		
C 217	CEJA1R5M50	R 1	RS1/16S225J
C 219	CCSRCH471J50	R 2	RS1/16S225J
C 220	CKSRYP103K25	R 4	RS1/16S154J
C 230	CKSRYP103K25	R 5	RS1/16S391J
		R 6	RS1/16S223J
C 231	CCSRCH330J50		
C 232	CCSRCH150J50	R 7	RS1/16S123J
C 233	CKSQYB104K16	R 8	RS1/16S332J
C 234	CEJA330M10	R 9	RS1/16S473J
C 235	CKSRYP332K50	R 10	RS1/16S223J
		R 11	RS1/16S124J
C 236	CKSQYB473K16		
C 237	CCSRCH120J50	R 13	RS1/16S563J
C 239	CKSRYP472K50	R 15	RS1/16S271J
C 240	CEJAR47M50	R 16	RS1/16S104J
C 241	CKSQYB104K16	R 17	RS1/16S332J
		R 18	RS1/16S332J
C 242	CEJAR47M50		
C 243	CEJAR33M50	R 31	RS1/16S470J
C 244	CKSQYB473K16	R 32	RS1/16S822J
C 245	CKSRYP333K16	R 33	RS1/16S822J
C 246	CKSQYB473K16	R 34	RS1/16S331J
		R 35	RS1/16S331J
C 250	CCSRCH471J50		
		R 51	RS1/16S271J
		R 52	RS1/16S560J
		R 55	RS1/16S102J
		R 56	RS1/16S823J
		R 61	RS1/16S392J
		R 62	RS1/16S273J
		R 101	RS1/16S272J
		R 102	RS1/16S682J
		R 103	RS1/16S333J
		R 104	RS1/16S334J
		R 105	RS1/16S683J
		R 107	RS1/16S222J
		R 151	RS1/16S222J
		R 152	RS1/16S393J
		R 155	RS1/16S273J
		R 156	RS1/16S243J
		R 157	RS1/16S203J
		R 160	RS1/16S222J
		R 161	RS1/16S563J
		R 162	RS1/16S105J
		R 163	RS1/16S223J
		R 202	RS1/16S223J
		R 203	RS1/16S225J
		R 204	RS1/16S103J
		R 206	RS1/16S220J
		R 207	RS1/16S101J
		R 208	RS1/16S102J
		R 209	RS1/16S471J
		R 214	RS1/16S822J
		R 215	RS1/16S822J
		R 217	RS1/16S102J
		R 231	RS1/16S272J
		R 232	RS1/16S473J
		R 237	RS1/16S103J
		R 238	RS1/16S104J
		R 239	RS1/16S104J
		R 240	RS1/16S332J
		R 241	RS1/16S202J
		R 243	RS1/16S183J
		R 244	RS1/16S392J
		R 247	RS1/16S123J

**B** Unit Number : CWE1486 (KEH-1850/X1M/ES)  
 Unit Name : FM/AM Tuner Unit

## MISCELLANEOUS

IC 1	IC	PA4023B	R 62	RS1/16S273J
IC 2	IC	PA4024A	R 101	RS1/16S272J
Q 1	Transistor	2SC2412K	R 102	RS1/16S682J
Q 2	Transistor	DTC124EU	R 103	RS1/16S333J
Q 3	FET	3SK263	R 104	RS1/16S334J
Q 31	Transistor	2SC2412K	R 105	RS1/16S683J
Q 201	FET	2SK932	R 107	RS1/16S222J
Q 202	Transistor	2SC2412K	R 151	RS1/16S222J
Q 203	Transistor	DTC124EU	R 152	RS1/16S393J
D 1	Diode	RD39JS	R 155	RS1/16S273J
D 2	Diode	RD39JS	R 156	RS1/16S243J
D 4	Diode	1SV250	R 157	RS1/16S203J
D 5	Diode	KV1410-F1	R 160	RS1/16S222J
D 6	Diode	MA157	R 161	RS1/16S563J
D 7	Diode	KV1410-F1	R 162	RS1/16S105J
D 8	Diode	KV1410-F1	R 163	RS1/16S223J
D 201	Diode	MA157	R 202	RS1/16S223J
D 202	Diode	MA157	R 203	RS1/16S225J
D 231	Diode	SVC253	R 204	RS1/16S103J
L 2	Coil	CTC1133	R 206	RS1/16S220J
L 3	Inductor	LCTB2R2K2125	R 207	RS1/16S101J
L 4	Coil	CTC1133	R 208	RS1/16S102J
L 5	Coil	CTC1132	R 209	RS1/16S471J
L 6	Inductor	LCTBR15K1608	R 214	RS1/16S822J
L 51	Ferri-Inductor	LAU150K	R 215	RS1/16S822J
L 201	Ferri-Inductor	LAU4R7K	R 217	RS1/16S102J
L 202	Ferri-Inductor	LAU330K	R 231	RS1/16S272J
L 203	Inductor	CTF1287	R 232	RS1/16S473J
L 208	Inductor	LAU121K	R 237	RS1/16S103J
L 231	Inductor	LCTA3R3J3225	R 238	RS1/16S104J
T 31	Coil	CTE1117	R 239	RS1/16S104J
T 51	Coil	CTC1159	R 240	RS1/16S332J
CF 51	Ceramic Filter	CTF1441	R 241	RS1/16S202J
CF 52	Ceramic Filter	CTF1441	R 243	RS1/16S183J
CF 53	Ceramic Filter	CTF1441	R 244	RS1/16S392J
			R 247	RS1/16S123J

====Circuit Symbol and No.====Part Name	Part No.
<b>CAPACITORS</b>	
C 1	CCSQCH6R0D50
C 2	CCSRCK2R0C50
C 4	CCSRCH820J50
C 6	CCSRCH820J50
C 8	CKSRYP103K25
C 9	CKSQYB104K16
C 10	CCSRCKR50C50
C 11	CEJA1R0M50
C 12	CKSRYP222K50
C 13	CKSRYP222K50
C 14	CCSRCH220J50
C 15	CCSRCH6R0D50
C 16	CCSRCH8R0D50
C 17	CKSRYP222K50
C 18	CKSRYP103K25
C 19	CKSRYP222K50
C 20	CKSRYP222K50
C 21	CEJA100M16
C 22	CCSRTH9R0D50
C 23	CCSRTH120J50
C 24	CCSRCH471J50
C 25	CKSRYP103K25
C 31	CKSRYP103K25
C 32	CKSQYB472K50
C 33	CCSRCH5R0C50
C 34	CKSQYB104K16
C 36	CCSRRH201J50
C 51	CKSRYP223K25
C 52	CKSRYP103K25
C 54	CCSRCH470J50
C 55	CKSQYB223K25
C 56	CKSQYB104K16
C 57	CKSRYP472K50
C 58	CEJA330M10
C 59	CKSRYP103K25
C 60	CKSRYP102K50
C 61	CCSRCH270J50
C 62	CKSRYP103K25
C 63	CEJAR22M50
C 101	CEJANP100M10
C 102	CKSRYP182K50
C 103	CKSRYP682K25
C 104	CEJA2R2M50
C 105	CKSRYP103K25
C 106	CCSRCH151J50
C 107	CKSRYP103K25
C 151	CKSRYP472K50
C 152	CKSQYB104K16
C 153	CEJA3R3M50
C 154	CKSQYB104K16
C 157	CEJA3R3M50
C 158	CKSYB474K16
C 159	CEJA220M6R3
C 160	CKSQYB104K16
C 161	CKSQYB104K16
C 162	CEJA3R3M50
C 163	CKSRYP102K50
C 170	CCSRCH100D50
C 201	CCSRCH471J50
C 202	CCSRCH100D50
C 203	CKSRYP332K50
C 204	CKSQYB473K16
C 205	CKSQYB473K16
C 206	CKSQYB104K16
C 207	CCSRCH560J50

====Circuit Symbol and No.====Part Name	Part No.
C 209	CKSQYB104K16
C 211	CCSRCH101J50
C 212	CEJA470M6R3
C 213	CKSRYP103K25
C 216	CCSRCH101J50
C 217	CEJA1R5M50
C 219	CCSRCH471J50
C 220	CKSRYP103K25
C 230	CKSRYP103K25
C 231	CCSRCH330J50
C 232	CCSRCH150J50
C 233	CKSQYB104K16
C 234	CEJA330M10
C 235	CKSRYP332K50
C 236	CKSQYB473K16
C 237	CCSRCH120J50
C 239	CKSRYP472K50
C 240	CEJAR47M50
C 241	CKSQYB104K16
C 242	CEJAR47M50
C 243	CEJAR33M50
C 244	CKSQYB473K16
C 245	CKSRYP333K16
C 246	CKSQYB473K16
C 250	CCSRCH471J50

**D** Unit Number :  
Unit Name : Cassette PCB

S 1	Switch(Load)	ESN1016
S 2	Switch(Mute)	ESN1017
S 3	Switch(FWD/REV)	ESH1006
S 4	Switch(Eject)	ESG1006
R 1		RD1/4HM472J

Miscellaneous Parts List

M 1	Motor Unit	EXA1467
HD 1	Head Assy	EXA1466
FU 951	Fuse 10A	CEK1136

## 6. ADJUSTMENT

### ● Connection Diagram

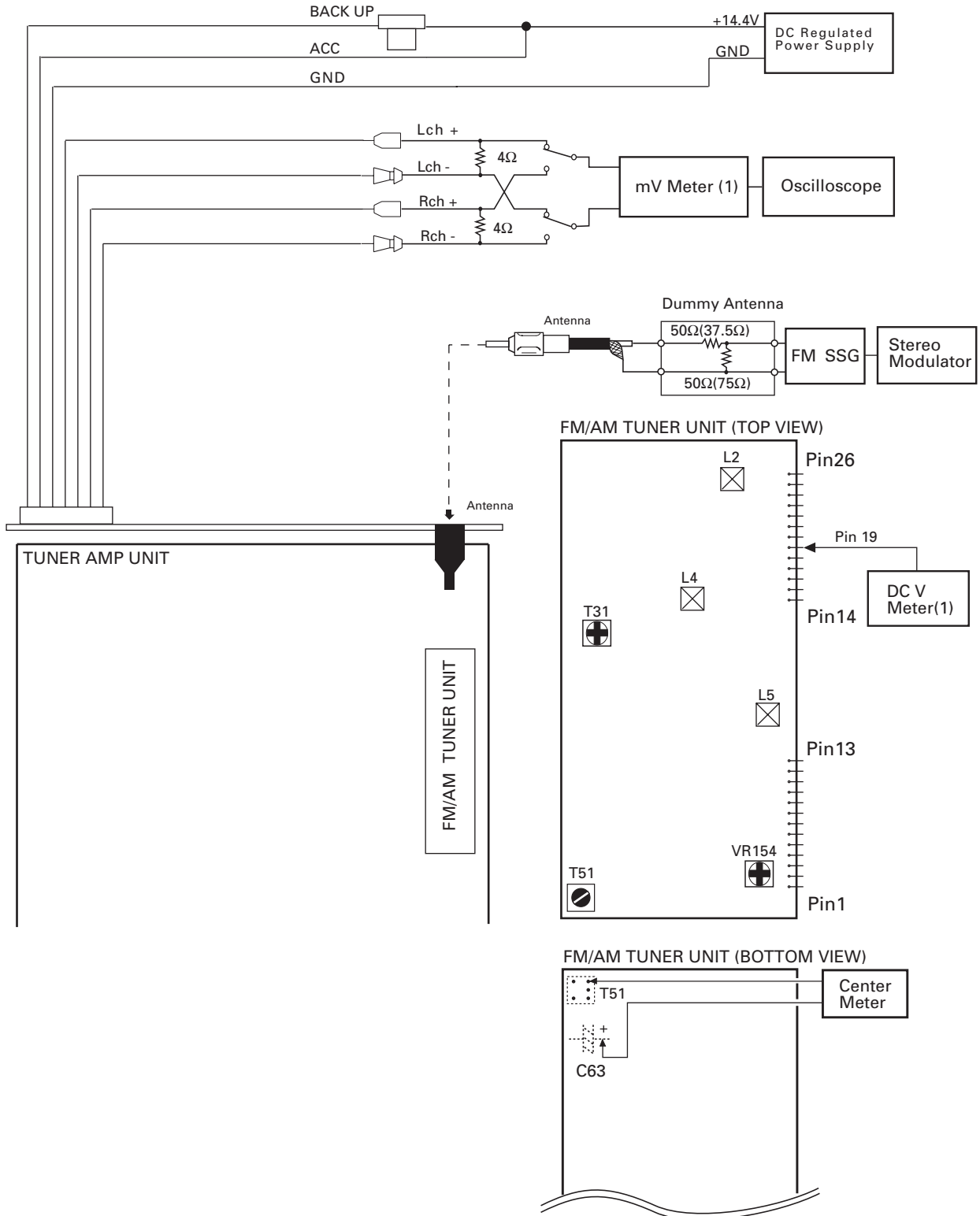



**FM ADJUSTMENT**

Modulation M:MONO MOD., 400Hz 30%(22.5kHz Dev.) or 400Hz 100%(75kHz Dev.)

S:STEREO MOD., 1kHz, L or R=30%(20.25kHz+7.5kHz Dev.)

NOTE:Before proceeding to further adjustments after switching power ON, let the tuner run for ten minutes to allow the circuits to stabilize.

**FM ADJUSTMENT(UC MODEL)**

	No.	FM SSG		Displayed Frequency(MHz)	Adjustment Point	Adjustment Method (Switch Position)
		Frequency(MHz)	Level(dBf)			
TUN Volt	1	••••	••••	107.9	L5	DC V Meter(1) : 6V
IF	2	98.1 M	60—100	98.1	T51	Center Meter : 0
ANT Coil	3	98.1 M	5	98.1	L2	mV Meter(1) : Maximum
RF Coil	4	98.1 M	5	98.1	L4	mV Meter(1) : Maximum
IFT	5	98.1 M	5	98.1	T31	mV Meter(1) : Maximum (STEREO MODE)
ARC	6	98.1 S	40	98.1	VR154	mV Meter(1) : Separation 5dB (STEREO MODE)

**FM ADJUSTMENT(ES MODEL)**

	No.	FM SSG		Displayed Frequency(MHz)	Adjustment Point	Adjustment Method (Switch Position)
		Frequency(MHz)	Level(dBf)			
TUN Volt	1	••••	••••	108.0	L5	DC V Meter(1) : 6V
IF	2	98.1 M	60—100	98.1	T51	Center Meter : 0
ANT Coil	3	98.1 M	5	98.1	L2	mV Meter(1) : Maximum
RF Coil	4	98.1 M	5	98.1	L4	mV Meter(1) : Maximum
IFT	5	98.1 M	5	98.1	T31	mV Meter(1) : Maximum (STEREO MODE)
ARC	6	98.1 S	40	98.1	VR154	mV Meter(1) : Separation 5dB (STEREO MODE)

## 7. GENERAL INFORMATION

### 7.1 PARTS

#### 7.1.1 IC

SN761029DL

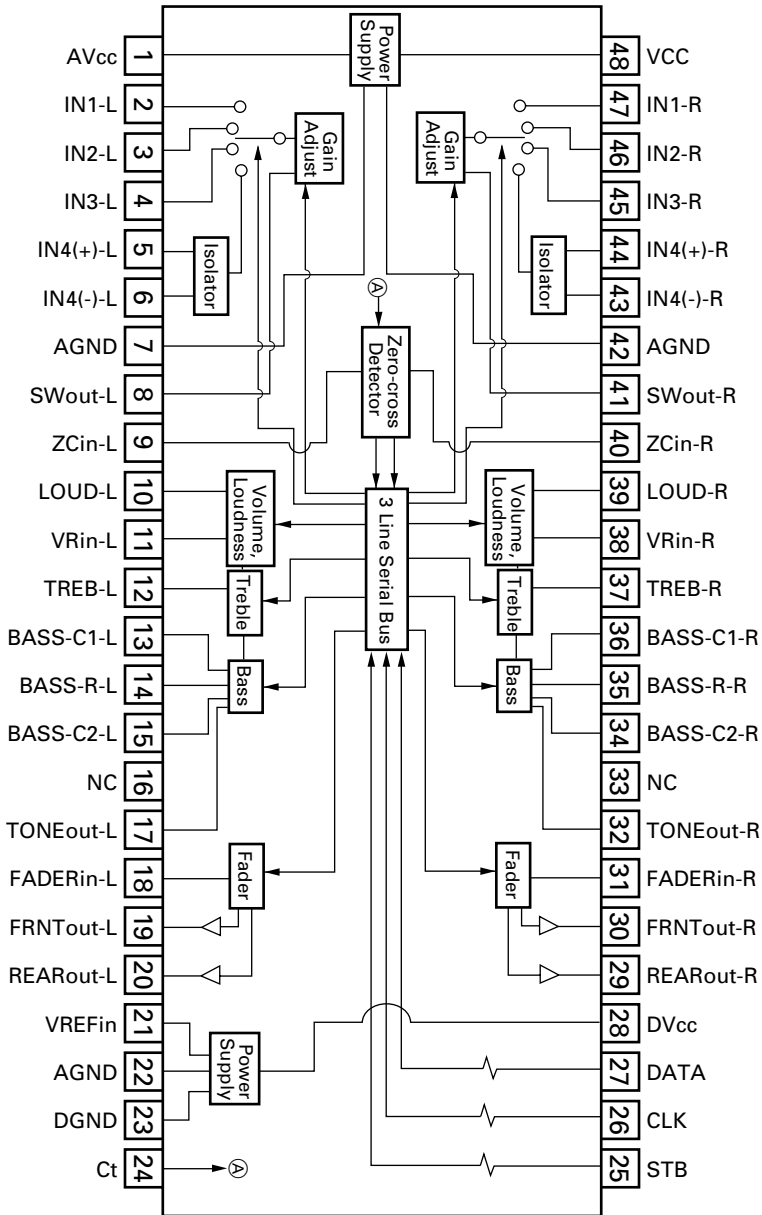

● Pin Functions(PE5017B)

Pin No.	Pin Name	I/O	Format	Function and Operation
1,2	NC			Not used
3	ADPW			A/D converter power
4	GND			GND
5,6	NC			Not used
7	AVREF1			(Connect to VDD)
8	KYDT	I		Key data input
9	DPDT	O	C	Display data output
10	$\overline{\text{DSENS}}$	I		Grille detach sense input
11	TUNPDI	I		PLL IC data input
12	TUNPDO	O	C	PLL IC data output
13	TUNPCK	O	C	PLL IC clock output
14	TUNPCE	O	C	PLL IC chip enable output
15-21	NC			Not used
22	$\overline{\text{SWVDD}}$	O	C	Grille power supply control output
23	NC			Not used
24	VDT	O	C	Data output for electronic volume
25	VCK	O	C	Clock output for electronic volume
26	VST	O	C	Strobe pulse output for electronic volume
27	SYSPW	O	C	System power supply control output
28	$\overline{\text{MUTE}}$	O	C	System mute output
29	DMINH	O	C	Mechanism mute cancel output
30-32	NC			Not used
33	GND			GND
34-37	NC			Not used
38	FM	O	C	FM power control output
39	AM	O	C	AM power control output
40-49	NC			Not used
50	EJECT	I		Eject key input
51	$\overline{\text{TAPLD}}$	I		Tape loading input
52	MECPW	O	C	Cassette mechanism power output
53	$\overline{\text{MCMUT}}$	I		Mechanism mute input
54	$\overline{\text{NOR/REV}}$	I		Normal reverse input
55-59	NC			Not used
60	RESET	I		Reset input
61,62	NC			Not used
63	$\overline{\text{CLKIN}}$	I		Clock input
64	$\overline{\text{ASENS}}$	I		ACC power sense input
65	$\overline{\text{BSENS}}$	I		Back up power sense input
66	SD	I		SD input
67	ST	I		FM stereo input
68	VDD			Power supply
69	X2			Oscillator output
70	X1			Oscillator input
71	GND			GND
72	NC			Not used
73	TESTIN	I		Test program mode input
74	AVDD			A/D converter analog power supply (VDD)
75	AVREF0			(A/D converter standard voltage input)
76	SL	I		Signal level input
77	MODEL	I		Model select input
78-80	NC			Not used

\*PE5017B

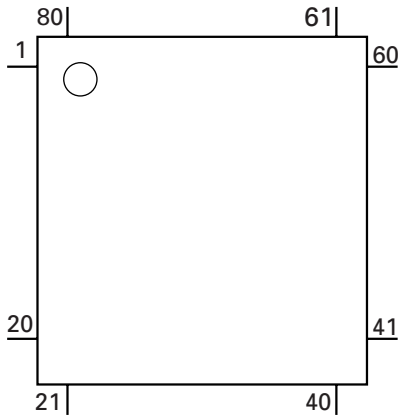

Format	Meaning
C	C MOS

IC's marked by\* are MOS type.  
Be careful in handling them because they are very liable to be damaged by electrostatic induction.

● Pin Functions (PD6293A)

Pin No.	Pin Name	I/O	Function and Operation
1-5	SEG4-0	O	LCD segment output 4-0
6-8	COM1-3	O	Common driver output 1-3
9	COM0	O	Common driver output 0
10	LCDB		LCD bias power supply
11-14	KS3-0	O	Key strobe output 3-0
15,16	KDT0,1	I	Key data input 0,1
17	REM	I	Remote control reception
18	DPDT	I	Display data input
19	NC		Not used
20	KYDT	O	Key data output
21	MODA		GND
22	X0		Crystal oscillator connection pin
23	X1		Crystal oscillator connection pin
24	VSS		GND
25,26	KDT2,3	I	Key data input 2,3
27,28	KST5,4	O	Key strobe output 5,4
29-55	SEG39-13	O	LCD segment output 39-13
56	VCC		5V
57-64	SEG12-5	O	LCD segment output 12-5

\*PD6293A

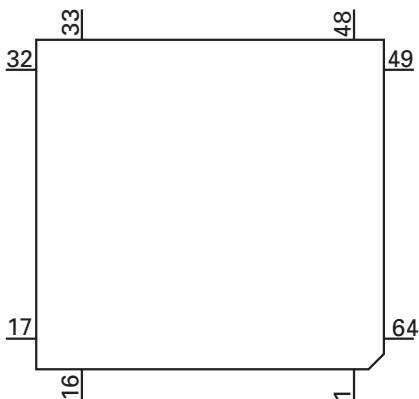



7.1.2 DISPLAY

● CAW1513

SEGMENT

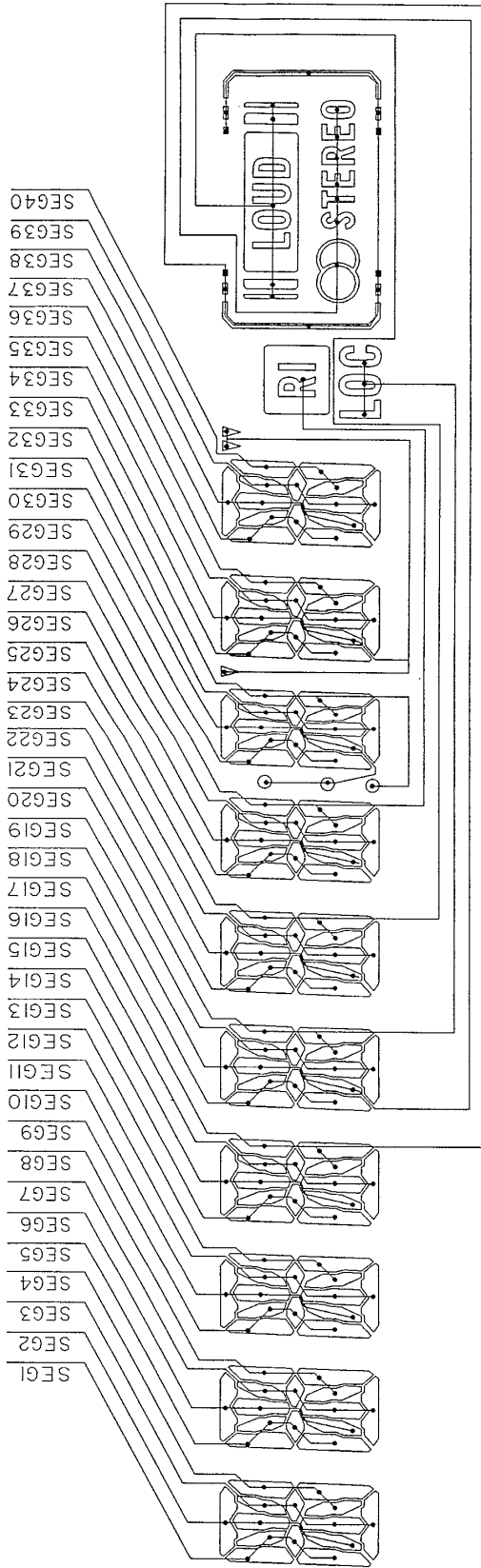

COMMON

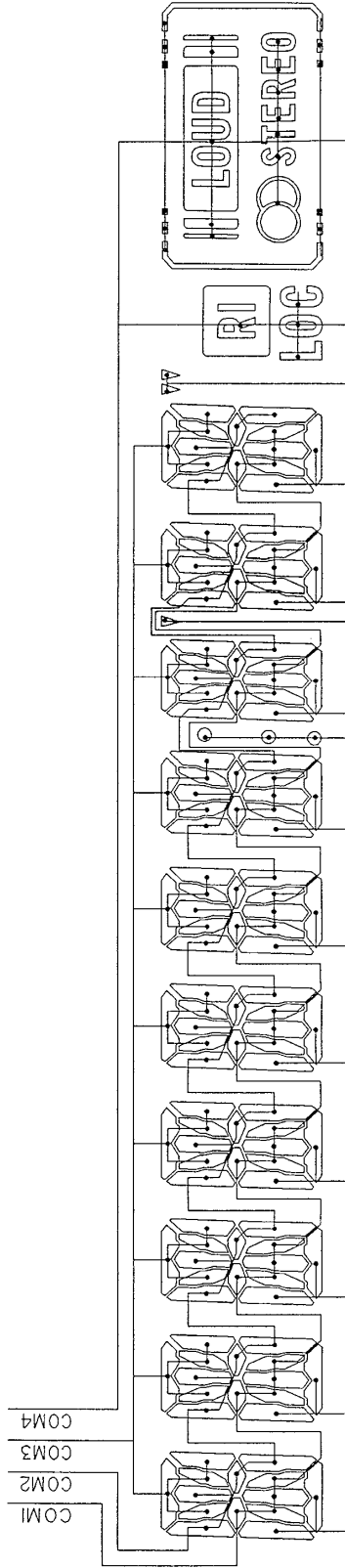

## 7.2 DISASSEMBLY

### ● Removing the Case(not shown)

- 1.Remove the three screws.
- 2.Remove the Case.

### ● Removing the Cassette Mechanism Assy (not shown)

- 1.Remove the four screws.
- 2.Disconnect the connector, and then removing the Cassette Mechanism Assy.

### ● Removing the Panel Unit(Fig.1)

- 1** Disengage the stopper at two locations indicated
- 2** Remove the Panel Unit.

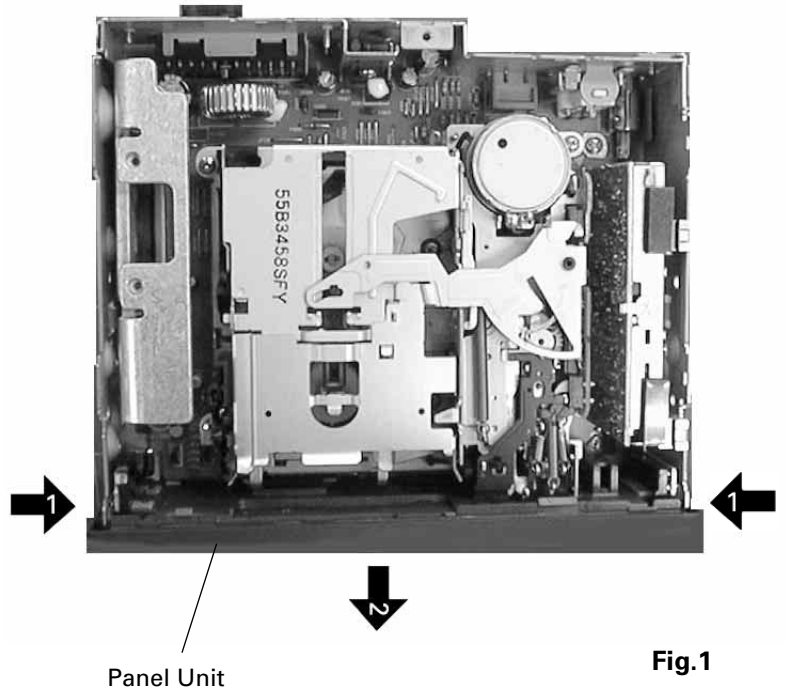
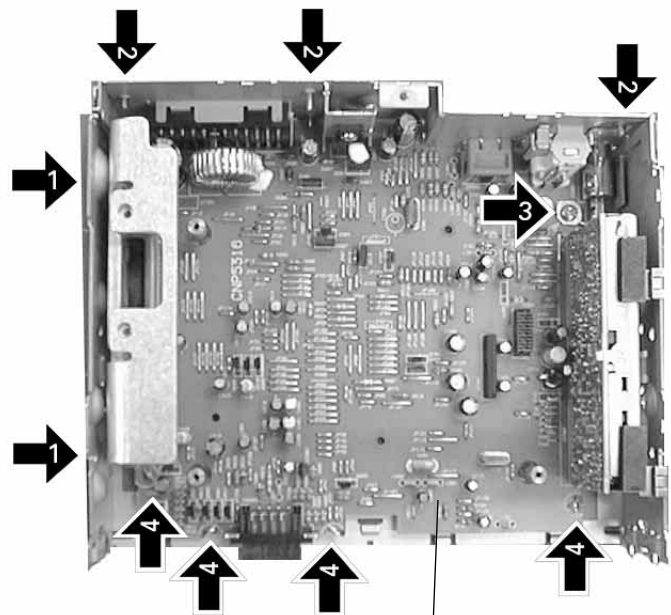

Fig.1

### ● Removing the Tuner Amp Unit(Fig.2)

- 1** Removing the two screws.
- 2** Removing the three screws.
- 3** Removing the screw.
- 4** Unbend the tabs at four locations indicated by arrow until straight. Remove the Tuner Amp Unit.



Tuner Amp Unit

Fig.2

### 7.3 BLOCK DIAGRAM

● KEH-1800/X1M/UC

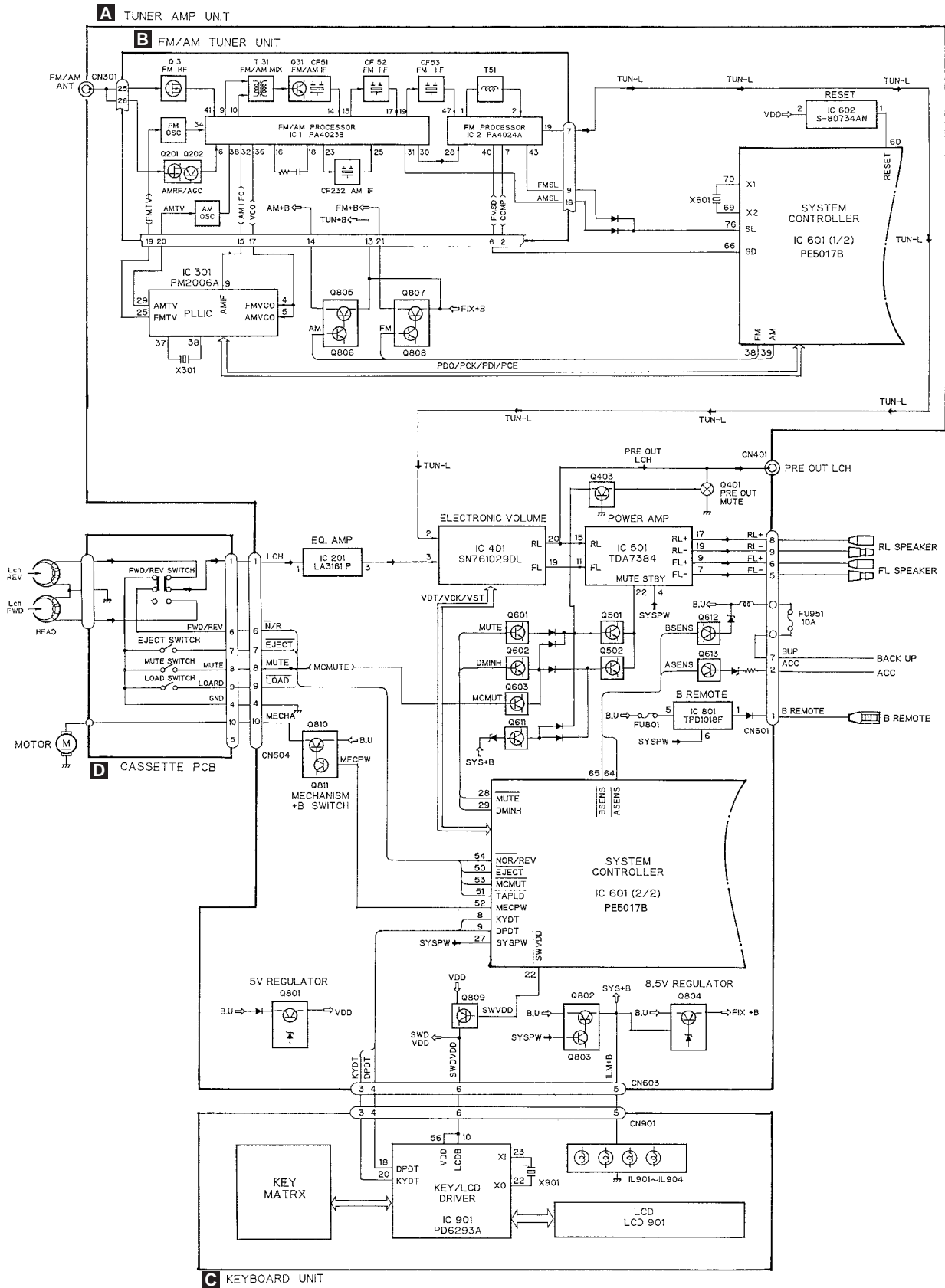



## 8. OPERATIONS AND SPECIFICATIONS

### Connection Diagram

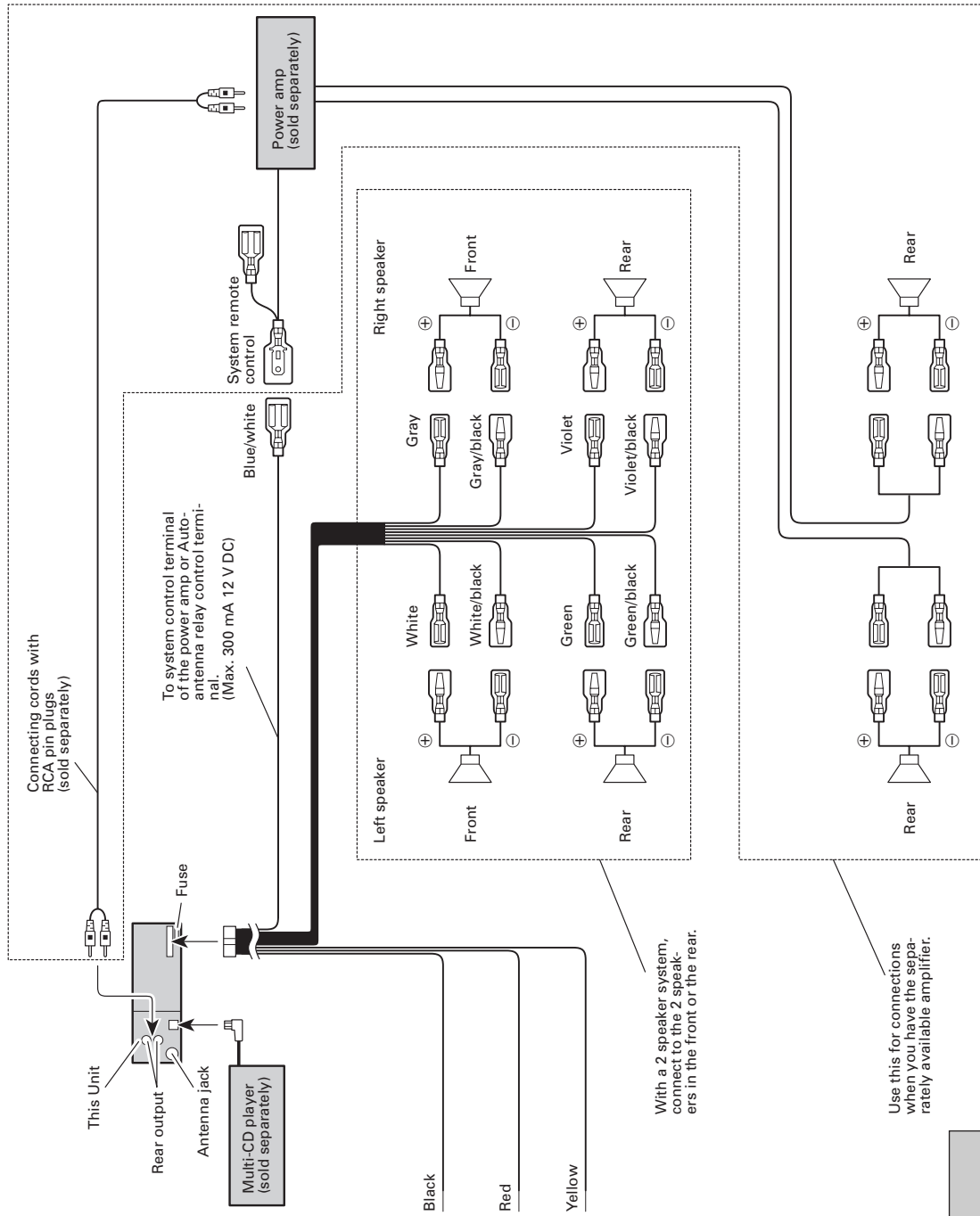

To vehicle (metal) body.

To electric terminal controlled by ignition switch (12 V DC) ON/OFF.

To terminal always supplied with power regardless of ignition switch position.

#### CAUTION

- Cords for this unit and those for other units may be different colors even if they have the same function. When connecting this unit to another unit, refer to the supplied Installation manuals of both units and connect cords that have the same function.

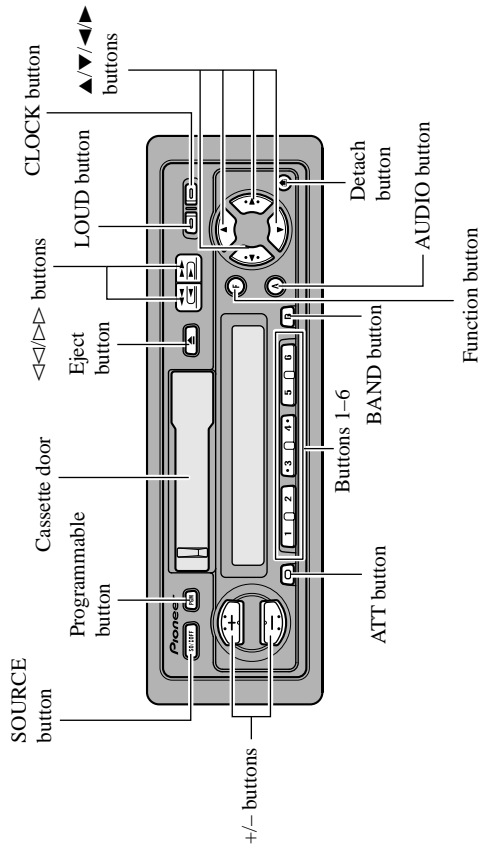

**Basic Operation of Cassette Player**

1. Insert the cassette tape.

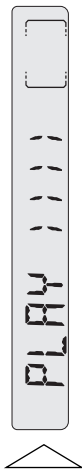
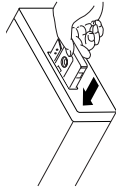

2. Switch tape playback from side A to side B, or vice versa.

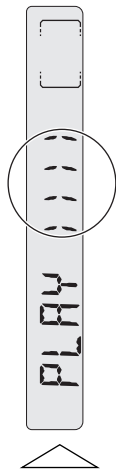
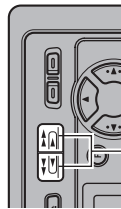

3. Raise or lower the volume.

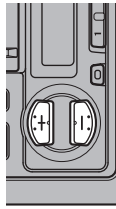

4. Remove the cassette tape.

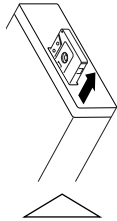

**Note:**

- The Tape function can be turned ON/OFF with the cassette tape remaining in this product.

## Tuner Operation

### Basic Operation of Tuner

**1. Select Tuner.**

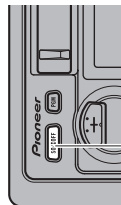

Each press changes the Source ...

Frequency appears on the display.

("STEREO" indicator lights when a stereo station is selected.)



**2. Select the desired band.**

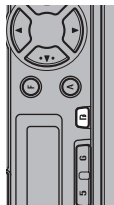

F1 → FII → FIII → AM

**3. Tune the receiver to a higher or lower frequency.**

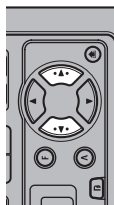

This product's tuner lets you select the tuning by changing the length of the time you press the button.

Manual Tuning (step by step)	0.3 seconds or less
Seek Tuning	0.3 – 2 seconds
Manual Tuning (continuously)	2 seconds or more

**Note:**

- To select a weak broadcasting station that cannot be tuned in with the Seek Tuning function, tune in with Manual Tuning.

## Tuner Operation

**4. Raise or lower the volume.**

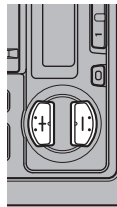

**5. Turn the source OFF.**

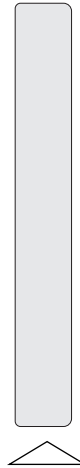
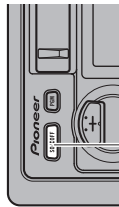

Hold for 1 second

### Entering the Function Menu

In this menu you can select tuner functions.

- Select the desired mode in Function Menu.

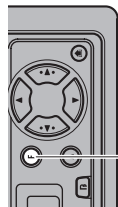

Each press changes the Mode ...

Each press of the Function button selects the mode in the following order:  
BSM → LOCAL

**Note:**

- You can cancel the Function Menu by pressing the BAND button.
- After selecting the Function Menu, if you do not perform an operation within about 30 seconds, the Function Menu is automatically canceled.

**General**

Power source ..... 14.4 V DC (10.8 – 15.1 V allowable)  
 Grounding system ..... Negative type  
 Max. current consumption ..... 8.5 A  
 Dimensions  
 (DIN) (chassis) ..... 178 (W) × 50 (H) × 150 (D) mm  
 [7 (W) × 2 (H) × 5-7/8 (D) in.]  
 (nose) ..... 188 (W) × 58 (H) × 19 (D) mm  
 [7-3/8 (W) × 2-1/4 (H) × 3/4 (D) in.]  
 (D) (chassis) ..... 178 (W) × 50 (H) × 155 (D) mm  
 [7 (W) × 2 (H) × 6-1/8 (D) in.]  
 (nose) ..... 170 (W) × 48 (H) × 14 (D) mm  
 [6-3/4 (W) × 1-7/8 (H) × 1/2 (D) in.]  
 Weight ..... 1.2 kg (2.6 lbs)

**Amplifier**

Continuous power output is 17 W per channel min. into 4 ohms, both channels driven 50 to 15,000 Hz with no more than 5% THD.  
 Maximum power output ..... 40 W × 4  
 Load impedance ..... 4 Ω (4 – 8 Ω allowable)  
 Preout maximum output level/output impedance ..... 2.2 V/1 kΩ

**Tone controls**

(Bass) ..... ±12 dB (100 Hz)  
 (Treble) ..... ±12 dB (10 kHz)  
 Loudness contour ..... +10 dB (100 Hz), +7 dB (10 kHz) (volume: -30 dB)

**Cassette player**

Tape ..... Compact cassette tape (C-30 – C-90)  
 Tape speed ..... 4.76 cm/sec. (+0.14cm/sec., -0.05cm/sec.)  
 Fast forward/rewinding time ..... Approx. 90 sec. for C-60  
 Wow & flutter ..... 0.13% (WRMS)  
 Frequency response ..... 40 – 14,000 Hz (±3 dB)  
 Stereo separation ..... 45 dB  
 Signal-to-noise ratio ..... 52 dB (IHF-A network)

**FM tuner**

Frequency range ..... 87.9 – 107.9 MHz  
 Usable sensitivity ..... 11 dBf (1.0 μV/75 Ω, mono, S/N: 30 dB)  
 50 dB quieting sensitivity ..... 16 dBf (1.7 μV/75 Ω, mono)  
 Signal-to-noise ratio ..... 70 dB (IHF-A network)  
 Distortion ..... 0.3% (at 65 dBf, 1 kHz, stereo)  
 Frequency response ..... 30 – 15,000 Hz (±3 dB)  
 Stereo separation ..... 40 dB (at 65 dBf, 1 kHz)  
 Selectivity ..... 70 dB (2ACA)  
 Three-signal intermodulation (desire signal level) ..... 30 dBf (two undesire signal level: 100 dBf)

**AM tuner**

Frequency range ..... 530 – 1,710 kHz  
 Usable sensitivity ..... 18 μV (S/N: 20 dB)  
 Selectivity ..... 50 dB

**Note:**

- Specifications and the design are subject to possible modification without notice due to improvements.

**General**

Power source ..... 14.4 V DC (10.8 – 15.1 V allowable)  
 Grounding system ..... Negative type  
 Max. current consumption ..... 8.5 A  
 Dimensions  
 (DIN) (chassis) ..... 178 (W) × 50 (H) × 150 (D) mm  
 (nose) ..... 188 (W) × 58 (H) × 19 (D) mm  
 (D) (chassis) ..... 178 (W) × 50 (H) × 155 (D) mm  
 (nose) ..... 170 (W) × 48 (H) × 14 (D) mm  
 Weight ..... 1.2 kg

**Amplifier**

Continuous power output is 17 W per channel min. into 4 ohms, both channels driven 50 to 15,000 Hz with no more than 5% THD.  
 Maximum power output ..... 40 W × 4  
 Continuous power output (1% dist. at 1 kHz) ..... 17 W × 4  
 Load impedance ..... 4 Ω (4 – 8 Ω allowable)  
 Preout maximum output level/output impedance ..... 2.2 V/1 kΩ

**Tone controls**

(Bass) ..... +8 – -16 dB (100 Hz)  
 (Treble) ..... ±12 dB (10 kHz)  
 Loudness contour ..... +10 dB (100 Hz), +7 dB (10 kHz) (volume: -30 dB)

**Cassette player**

Tape ..... Compact cassette tape (C-30 – C-90)  
 Tape speed ..... 4.76 cm/sec. (+0.14cm/sec., -0.05cm/sec.)  
 Fast forward/rewinding time ..... Approx. 90 sec. for C-60  
 Wow & flutter ..... 0.13% (WRMS)  
 Frequency response ..... 40 – 14,000 Hz (±3 dB)  
 Stereo separation ..... 45 dB  
 Signal-to-noise ratio ..... 52 dB (IHF-A network)

**FM tuner**

Frequency range ..... 87.5 – 108 MHz  
 Usable sensitivity ..... 11 dBf (1.0 μV/75 Ω, mono, S/N: 30 dB)  
 50 dB quieting sensitivity ..... 16 dBf (1.7 μV/75 Ω, mono)  
 Signal-to-noise ratio ..... 70 dB (IHF-A network)  
 Distortion ..... 0.3% (at 65 dBf, 1 kHz, stereo)  
 Frequency response ..... 30 – 15,000 Hz (±3 dB)  
 Stereo separation ..... 40 dB (at 65 dBf, 1 kHz)

**AM tuner**

Frequency range ..... 531 – 1,602 kHz (9 kHz)  
 Usable sensitivity ..... 18 μV (S/N: 20 dB)  
 Selectivity ..... 50 dB (±9 kHz)  
 50dB (±10 kHz)

**Note:**

- Specifications and the design are subject to possible modification without notice due to improvements.